

www.sur-ron.com

This manual contains the most current product information available at the time of printing, your motorcycle may look and setup differ from the information supplied in this owner's manual. Please visit our website for updates and additional information about your motorcycle.



STORM BEE owner's manual

This manual will provide you a better understanding of your electric motorcycle. Please take your time to read this manual carefully and all safety labels before riding.

This Manual covers the following motorcycles:

STORM BEE R (road) All terrain

version

ABS (optional)

Headlight and Turn Signals

All terrain tires (19-inch diameter front and 17-inch diameter rear)

STORM BEE E (enduro) Trail version

ABS (optional)

Headlight and Turn Signals

Off-road tire (21-inch diameter front and 18-inch diameter rear)

STORM BEE F (off road) Off-road

version

Off-road tire (21-inch diameter front and 18-inch diameter rear)

Riding tips for maximum range

Range varies in STORM BEE electric motorcycles similarly to how it varies in gas motorcycles. The range variety of STORM BEE electric motorcycles comes from the riding application after each full charge. In addition to riding habits, energy consumption is also affected by environmental conditions (such as extreme cold or hot weather, riding on steep soft road, etc.). To achieve the maximum range with a single charge, please pay attention to reduce the maximum speed, less sudden acceleration and maintain a constant speed to ensure the maximum range.

To reach the maximum range, please following the tips below:

- ① Avoid frequent and acute acceleration and braking.
- ② Under safe riding conditions, please reduce the riding speed by using the throttle to decelerate instead of pulling the brake lever. When you're riding the STORM BEE, if the motorcycle is moving and the throttle is in the idle position, the energy regenerative brake will reduce the speed of the STORM BEE and converting the kinetic energy to charge the battery pack.
- ③ Maintain a correct tire pressure (Please refer to Recommended tire pressure table page 10.12)
- ④ Remove unnecessary goods and reduce load.
- ⑤ The maximum range in winter or summer could be slightly different.

In conclusion, you can estimate your range according to the above factors and your riding habits.

Note: The range will be reduced according to the various tough road conditions during off-road riding.

Introduction	1.1
Important Notice	1.1
Transporting	1.2
Safety Information	2.1
Safe Riding Requirement	2.1
Important Information	2.2
Location of Important Labels	2.4
Operation and Component Locations	3.1
Display and Indicator	4.1
Dashboard Overview	4.1
Feature Setting	5.1
Dashboard Setting	5.1
System Feature Setting	5.3

Feature Introduction	6.1
Handlebar Controls	6.1
Riding mode Button	6.4
Parking Brake Operation	6.5
Battery Pack Removal	6.5
Battery Pack Installation	6.6
Starting and Operating	7.1
Check before riding	7.1
Key switch/ Steering lock	7.2
Riding	7.3
Parking	7.4
Temperature indicator	7.4
ABS (Anti-lock braking system)	7.5
Front fork adjustment	7.7
Rear shock adjustment	7.9

Power management	8.1
Battery Pack	8.1
Power and charging	8.2
Power system management	9.1
power system	9.1
Terminal Box	9.1
Maintenance Your Motorcycle	10.1
Maintenance Items	10.1
Maintain Records	10.1
Regular Maintenance	10.1
Maintenance Schedule	10.1
Torque Management	10.3
Battery Pack	10.5
Braking System	10.5
Liquid-cooling system	10.8
Reduction gearbox	10.10

Suspension system	10.11
Wheels and Tires	10.11
Chain	10.12
Headlight Adjustment	10.13
Light Bulb Replacement	10.14
Motorcycle Cleaning	10.15
Parking and Long-term Storage	10.16
Storm bee parts	10.16
Fuse	10.16
Electric Circuit diagram	10.19
Troubleshooting	11.1
Storm bee Troubleshooting	11.1
Precautions for hot and cold weather	11.1
Safety Interlock	11.2
Storm bee Precautions	11.2
System warning message	11.3
General troubleshooting	11.7

Warranty and after-sales information	12.1
Limited Warranty conditions	12.1
Warranty period for sales motorcycles	12.1
Parts Covered by warranty	12.2
Warranty Labor Coverage	12.2
General Exclusions from Warranty	12.2
Motorcycle owner responsibility.....	12.3
Warranty limitations	12.4
How to obtain warranty service	12.4
Annex	13.1
Maintenance Record Sheet	13.1
After-sales services record sheet	13.7
Comparison table of spec	13.9

Introduction

Important Notice

Congratulations and thank you for purchasing SURRON STORM BEE electric motorcycle. We sincerely welcome you to the community of SURRON electric motorcycle riders.

This manual is designed to provide you with a better understanding of the operation, maintenance requirements and troubleshooting of your electric motorcycle. Please take your time to read this manual carefully as well as all safety labels before riding. Please DO NOT use it until you understand the basic operation and features of the STORM BEE electric motorcycle.

You can also find this manual to download on our official website www.sur-ron.com. If there is any critical update, it will be released on the official website. Please visit our official website to get the latest version.

Please ensure that this manual stays with the motorcycle at all times, even when you resell it. If you have any questions regarding the operation or maintenance of your motorcycle, please contact the after-sales service department of Sur-ron at:

/// service@qiulongtech.com ///

Warning

If the power supply is damaged or the charging system malfunctioned, please contact your authorized dealer designated by the manufacturer immediately for replacement or repair.

Introduction

Transporting

It is highly recommended that the electric motorcycle be firmly secured on the transport frame using ratchet straps while it is being transported. It is recommended that the soft straps must be used to reduce scratches or other damages.

It is recommended to fix the ratchet straps according to the points shown in the figure. The front two are tied to the handlebar and the back two are tied to the left and right swing arm. Please do not damage the chain or brake line when tied the strap. The tie down straps should be at a 45° angle from the motorcycle. Follow the manufacturer's instructions for the ratchet straps you are using.

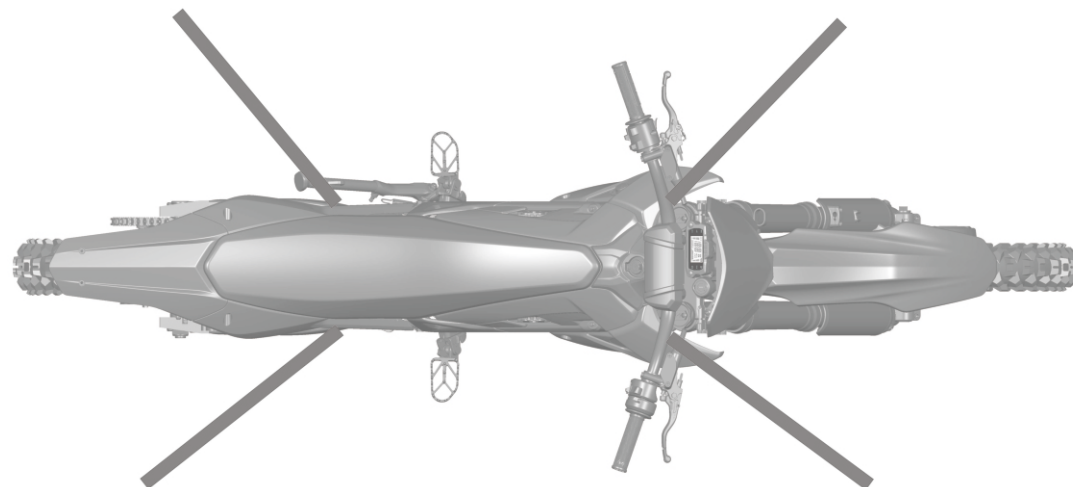

Safety Information

Safety Riding Requirement

Your electric motorcycle can provide many years of service and pleasure if you take responsibility for your own safety and understand the challenges you can meet while riding. There is a lot you can do to protect yourself whilst riding. You will find many helpful recommendations throughout this manual. The following are a few that we consider to be most important.

2.1

STORM BEE is a high performance electric motorcycle and should be treated with extreme caution.

Proper safety gear, including a regionally/nationally approved helmet, riding boots, eyewear, gloves, and protective clothing should be worn while riding to reduce the risk of potential injury. We highly recommend the use of full height motocross boots since the vast majority of motorcycle injuries are through leg and foot impact.

Read all warnings and instructions in this manual as well as all the safety labels before operating your electric motorcycle.

Never allow a guest to ride your electric motorcycle without proper instruction.

Ensure you have the legal qualification to ride the motorcycle before operation.

Never consume alcohol or drugs before operation of your electric motorcycle.

Persons unwilling or unable to take responsibility for their actions should not use this motorcycle. You assume all responsibility while operating your motorcycle. The seller assumes no liability for misuse or operator negligence.

Prior to each use, the rider must check everything in the “check before ride” section on page 7.1, and the charge level of the battery pack as indicated on the dashboard display charge indicator.

It is important to keep your motorcycle properly maintained and in safe riding condition. Having a breakdown can be difficult, especially if you are stranded off-road far from your base. To help avoid problems, inspect your motorcycle before every ride and perform all recommended maintenance according to the maintenance schedule and adjustment requirements listed in this manual. Be sure you understand the importance of checking all items thoroughly before riding. If you are the STORM BEE off-road version owner, please understand your

Safety Information

Important Information

Several important operation considerations are listed below:

Always turn the key switch(A) and motor stop switch(B) to the OFF position when not actively riding. It is extremely easy to forget that the motorcycle is still in standby mode because it is completely silent. An accident can occur if the motorcycle is left powered up while getting on or off the motorcycle.

2.2

motorcycle is designed and manufactured for off-road use only. The tires are not made for paved surface use and the motorcycle does not have Turn signals or other features required for use on public roads. If you need to cross a paved or public road, get off and walk your motorcycle across.

Modifications to the motorcycle may render the motorcycle unsafe and may cause severe personal injury. The manufacturer cannot be held liable for non-approved modifications.

Be very careful when loading or adding accessories to your motorcycle. Large, bulky, or heavy items may adversely affect the handling and performance of your motorcycle.

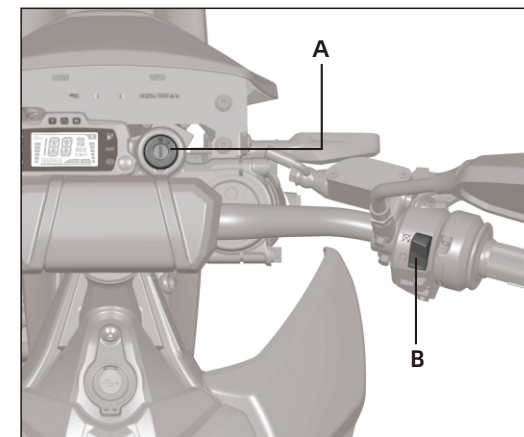

Safety Information

Turn the motor stop switch (B) OFF when pushing or moving the motorcycle.

Use the parking brake (C) when you are stopped on a ramp or steep hill. Do not hold partial throttle to keep the motorcycle stationary on a ramp or steep hill, it can trigger the locked rotor protection which cause the motorcycle to slip back.

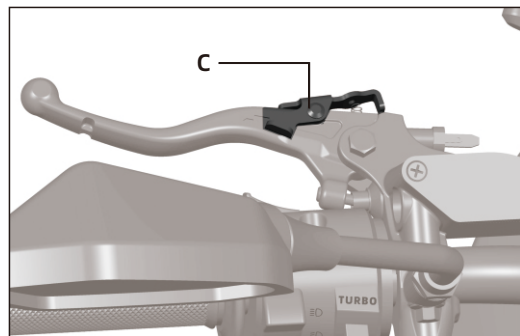

Please recharge the battery pack of your electric motorcycle after each use. Once fully charged, disconnect from AC power supply. Make sure that the charging is carried out in an open space or with monitoring.

While unplugged with the key in the OFF position, the

motorcycles electronic components will consume a small amount of power and the battery pack will drain extremely slowly. If you don't ride for an extended period of time (30 days or more), you may need to charge the electric motorcycle for a few hours prior to your next ride. The battery pack will be damaged if it is stored for a long time under low power.

CAUTION

Only charge the STORM BEE battery pack with the motorcycle's original charger or the manufacture approved accessory charger.

The battery pack does not require nor benefit from deep discharging. To get the most battery pack life, recharge the battery pack after each ride. Constantly leaving a battery pack in a deep discharging state will cause battery cell damage.

Failure to follow battery pack storage and charging instructions as described in this Manual may void the warranty of your STORM BEE electric Motorcycle. These guidelines have been rigorously tested to ensure maximum battery pack efficiency and service.

Safety Information

Location of Important Labels

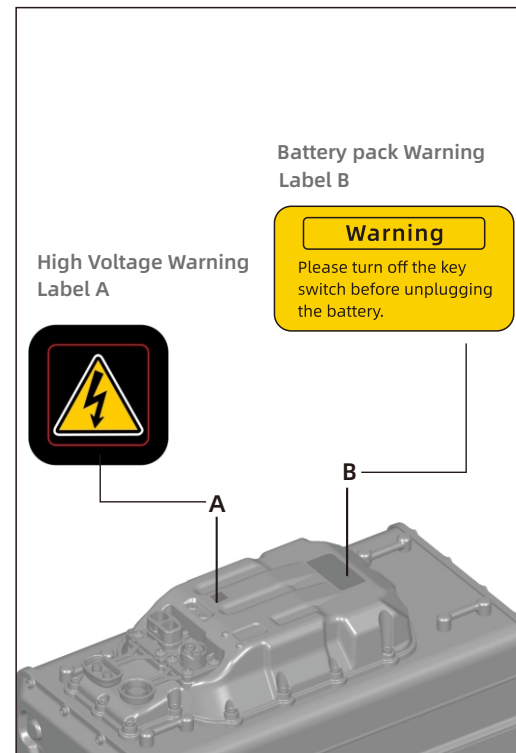

MCU Label A

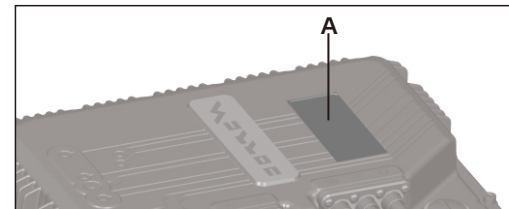

VIN label (A) The motorcycle chassis number information (B)

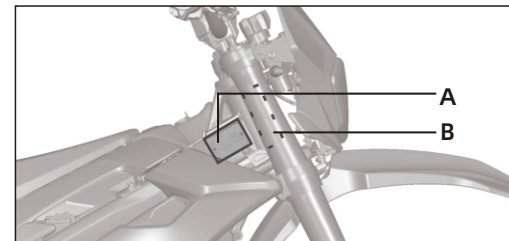

Motor Serial Number (A)

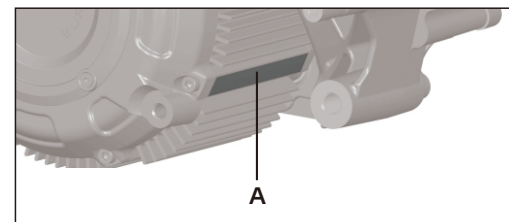

2.5



The motorcycle may have the following information for different sale region models:

- A. VIN label (Australia) - certification label
- B. VIN label (North American) - certification label
- C. VIN label (European Union) - certification label
- D. Tire and loading information labelE. VIN label

2.6

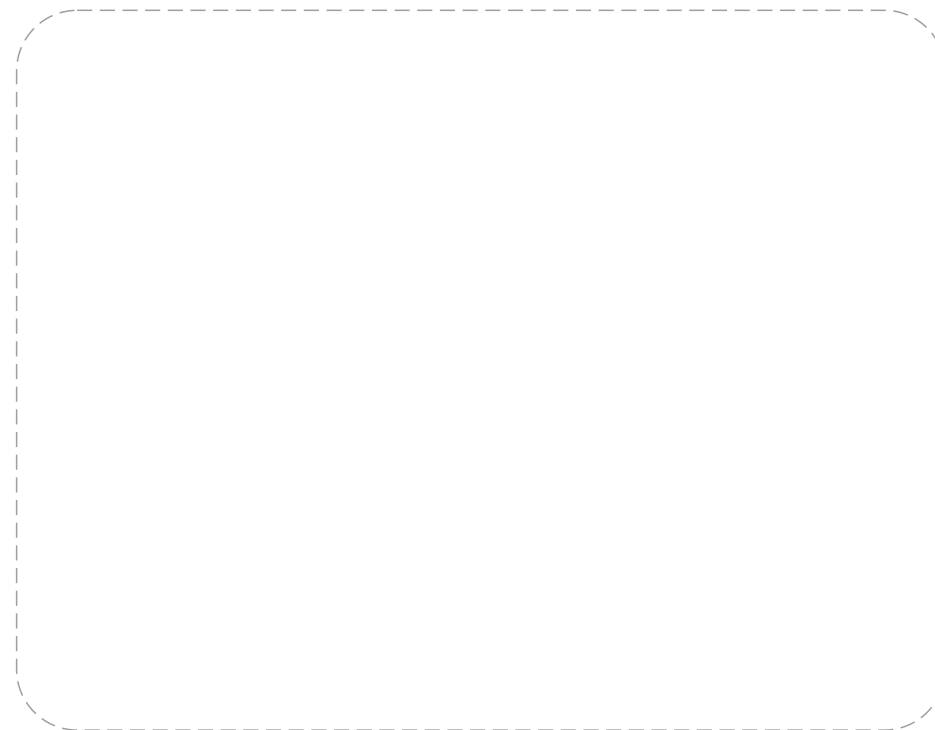

Operation and Component Locations

A. Mirrors

This STROM BEE electric motorcycle is equipped with convex mirrors. A convex mirror has a curved surface. Convex mirrors offer a greater field of view than a similar flat mirror. However, the greater field of view makes objects seem further away than they really are. Care must be used when judging the distance of objects seen in these mirrors.

B. Rear Brake Lever

For description and operation, see 'Feature Introduction', on page 6.1.

C. Parking Brake Lever

For description and operation, see 'Feature Introduction', on page 6.2.

D. Rear Brake Fluid Reservoir

For description and operation, see 'Maintenance', on page 10.5.

E. Left Handlebar Control

For description and operation, see 'Feature Introduction', on page 6.1.

F. Dashboard

For description and operation, see 'Display and

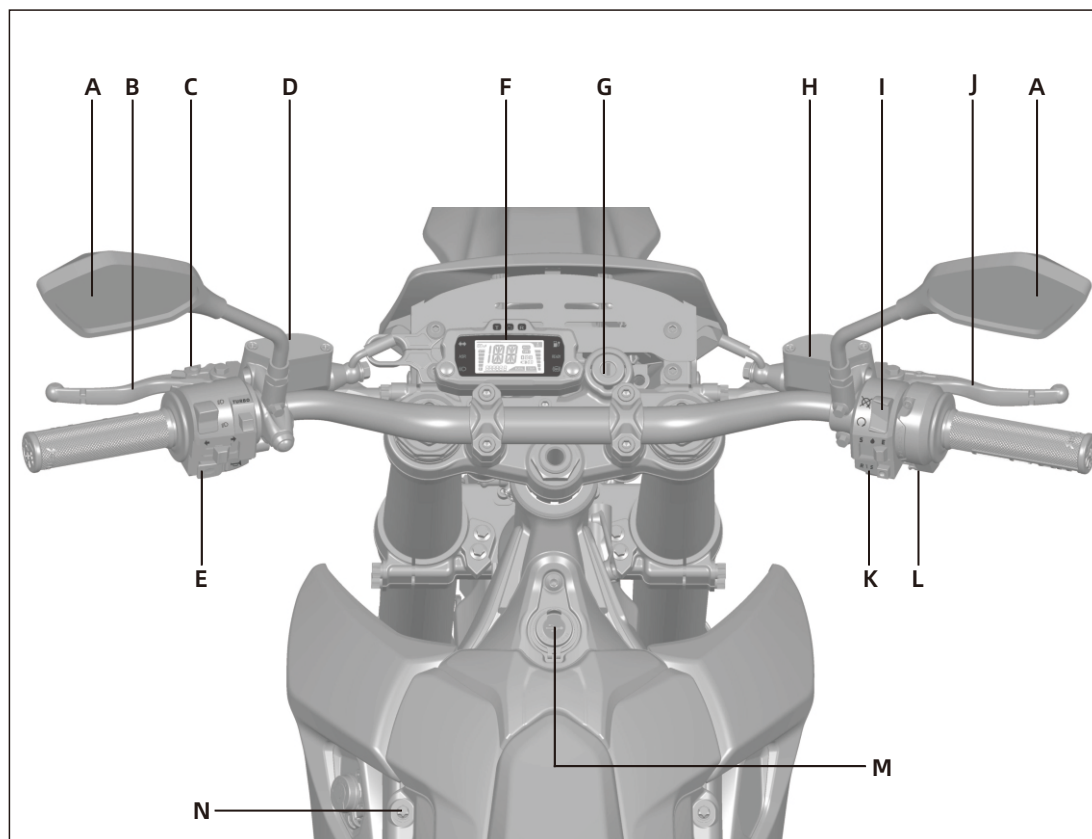

Operation and Component Locations

Indicator', on page 4.1. and 'Feature Setting', on page 5.1.

G. Key Switch/Steering Lock

For description and operation, see 'Starting and Operating', on page 7.2.

H. Front Brake Fluid Reservoir

For description and operation, see 'Maintenance', on page 10.5.

I. Motor Stop Switch

For description and operation, see 'Feature Introduction', on page 6.3.

J. Front Brake Lever

For description and operation, see 'Feature Introduction', on page 6.3.

K. Right Handlebar Control

For description and operation, see 'Feature Introduction', on page 6.3.

L. Throttle grip

For description and operation, see 'Feature Introduction', on page 6.3.

M. USB port

5V 2.4A USB port

N. Seat Installation bolt

Fix the seat on the frame, see 'Feature Introduction', on page 6.5.

Operation and Component Locations

A. Headlight

For headlight operation, see “Feature Introduction” , on page 6.2.

For headlight replacement, see “Maintenance” , on page 10.14.

For headlight alignment, see “Maintenance” , on page 10.13.

B. Front Turn Signals

For turn signals operation, see “Feature Introduction” , on page 6.3.

For turn signals replacement, see “Maintenance” , on page 10.14.

C. Integrated Charging port

For description and operation, see “Power Management” , on page 8.2.

D. Rear Turn Signals

For rear turn signals operation, see “Feature Introduction” , on page 6.3.

For rear turn signals replacement, see “Maintenance” , on page 10.14.

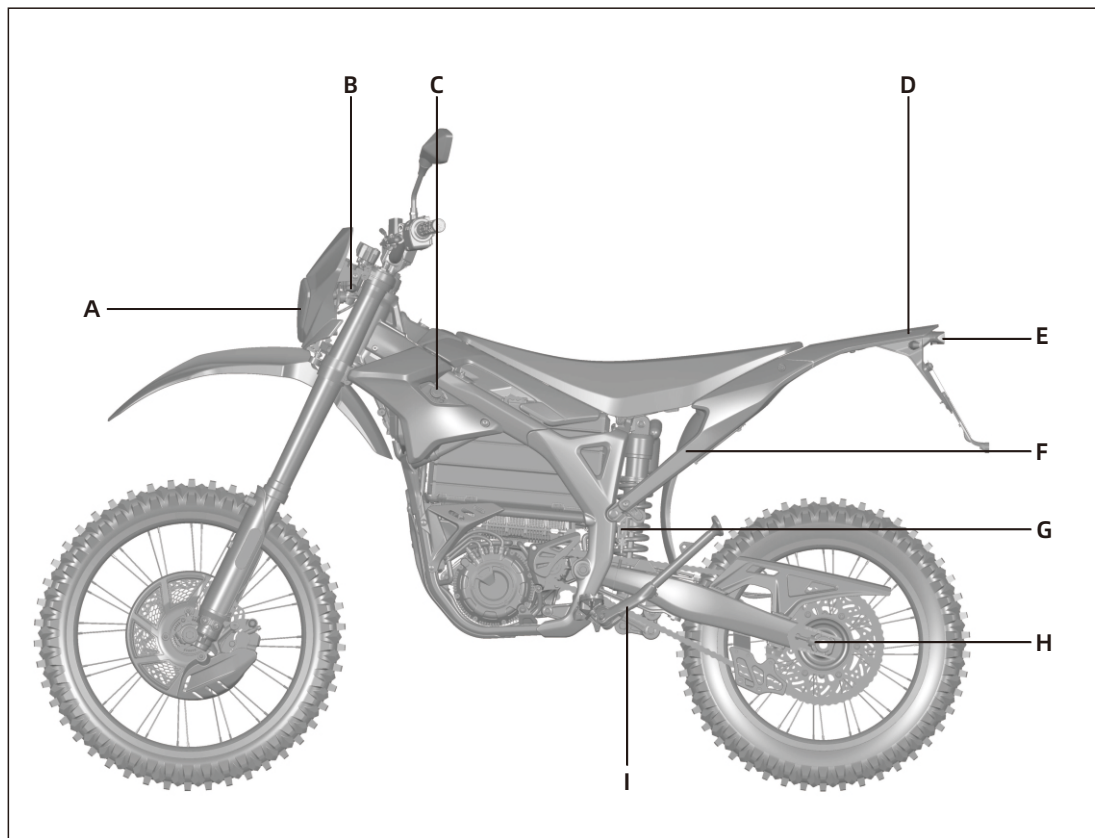

Operation and Component Locations

E. Brake/Tail/License plate Light

For Brake/Tail/License plate Light replacement, see “Maintenance” , on page 10.14.

F. Sidestand strap

This strap is a safety feature that prevents the sidestand down when riding causing you to lose control of the motorcycle and cause personal injury.

CAUTION

Park only on a flat firm surface, otherwise the motorcycle could fall over causing damage.

G. Sidestand Switch

This switch is a safety feature that prevents motor operation when the sidestand is down. If the sidestand were down when riding it could contact the ground causing you to lose control of the motorcycle and cause personal injury.

H. Chain Adjuster

Located on left and right side. See “Maintenance” , on page 10.9.

I. Sidestand

The sidestand supports the motorcycle when parked. The key switch should be in the OFF position when parked.

Operation and Component Locations

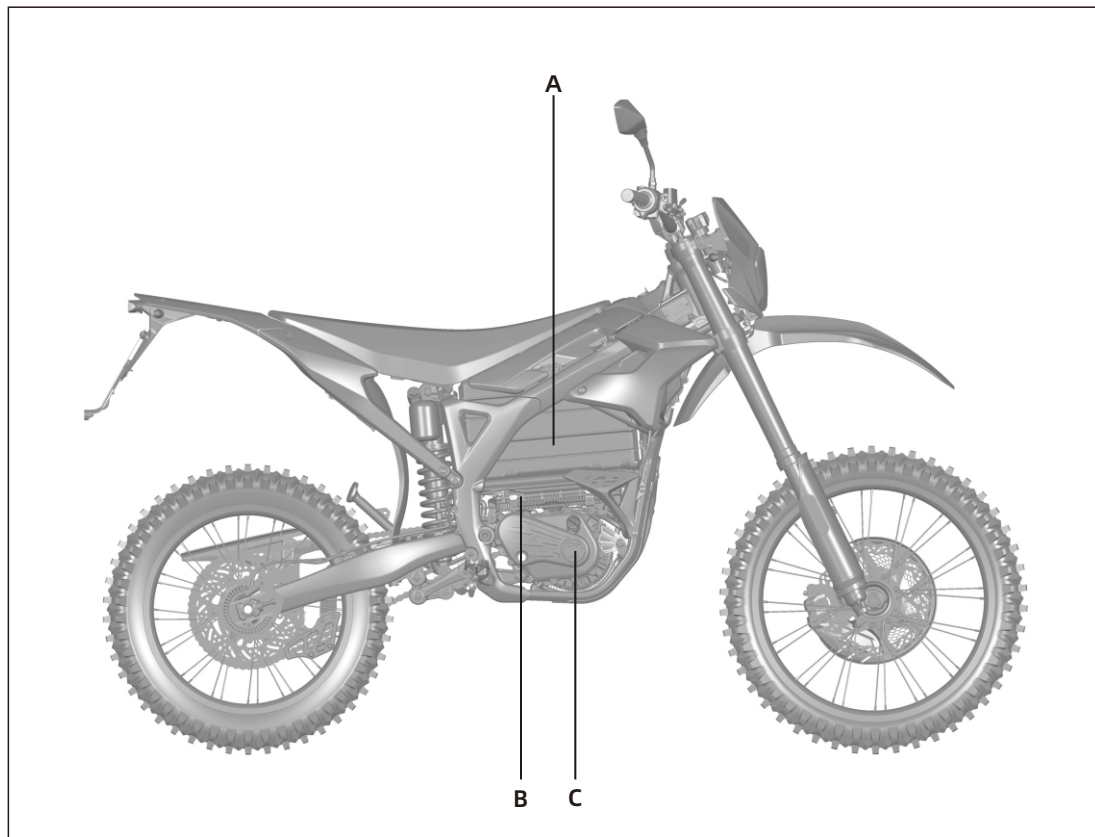

Operation and Component Locations

A. Battery pack

For description and operation, see 'Power Management', on page 8.1.

B. MCU

For description and operation, see 'Power System Management', on page 9.1.

C. Motor and Reduction gearbox

For description and operation, see 'Power System Management', on page 9.1.

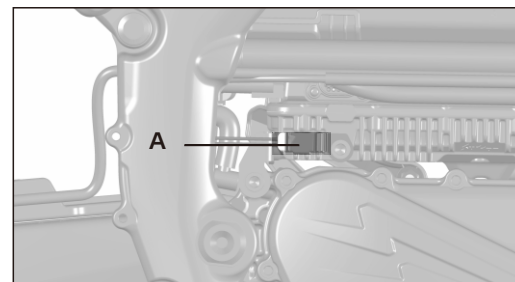

A. Temperature Sensor

Monitoring the temperature of the MCU, will activate the liquid-cooling system when necessary.

Display and Indicator

Dashboard Overview

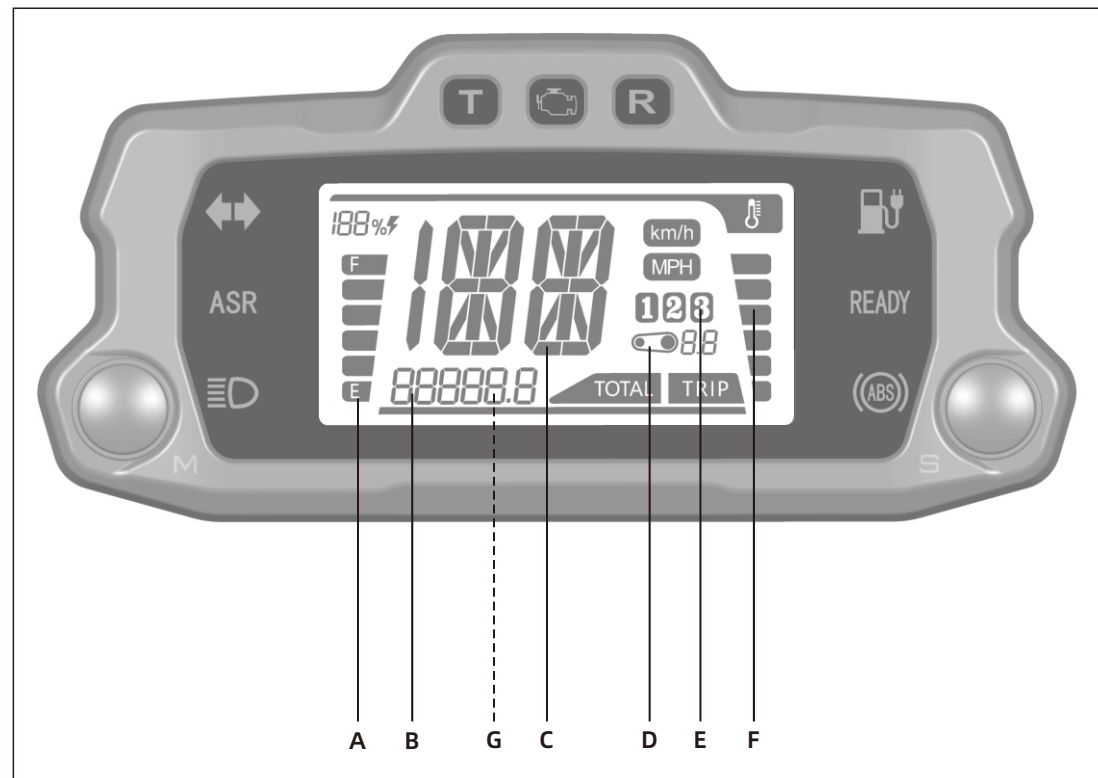

Display and Indicator

A. Charge Indicator

This indicator and readout display the amount of energy remaining in the battery pack similar to the fuel gauge on a gasoline powered motorcycle.

B. Odometer

The odometer displays the total distance the motorcycle has been ridden in kilometers or miles.

C. Speedometer

The speedometer is a digital display in either kilometers per hour (km/h) or miles per hour (mph). For description and operation, see "Feature Setting" , on page 5.2.

D. Transmission ratio Display

It displays the current transmission ratio of STORM BEE electric motorcycle.

E. Riding mode

This area displays the riding mode (1,2,3) corresponding to the Riding mode of ECO, RAIN and SPORT. The Riding mode button is located on the right handlebar assembly. For description and operation, see "Feature Introduction" , on page 6.4.

F. Temperature Indicator

The temperature indicator is on the right side of the LCD dashboard display, indicating the temperature of the motor, MCU and battery pack. When the temperature of one of these components exceeds the rated temperature limit, the temperature indicator will flash. For description and operation, see "Starting and Operating" , on page 7.4.

G. Warning Code Display

When the motorcycle fails, the corresponding Warning Code will be displayed. For Warning Code, see "Troubleshooting" on page 11.4

Display and Indicator

A. TURBO Mode Indicator

This indicator shows the working state of turbo mode. The indicator will disappear when turbo mode is not available. The indicator illuminates when turbo mode is available. If the indicator is flashing slowly, turbo mode is in use. If the indicator is flashing fast, turbo mode is about to end.



B. System Warning Indicator

There are two working states for the system warning indicator light. An orange flashing light indicates the power down state and if a fault has been detected, the indicator illuminates a solid orange light. See 'Troubleshooting' for detailed Warning Code, on page 11.7.



C. Reverse mode indicator (R)

The indicator illuminates when the motorcycle is in reverse mode; the indicator disappears when the motorcycle is out of reverse mode.



D. Turn Signals

Once the Turn Signals is switched on, the Turn signals remains flashing until the Turn signals request has been canceled.



E. ASR indicator

The Acceleration Slip Regulation feature is turned on and off by the ASR switch, and the ASR indicator turns on and off accordingly. When the Acceleration Slip Regulation (ASR) feature of the motorcycle is in the locked on state, this indicator illuminates. When the ASR indicator flashes, both the signal of the speed sensor and the ASR feature is abnormal. Please check whether the gap between the wheel speed sensor and the code disk is in the range of 0.8 ~ 1.2mm, and whether the wheel speed sensor is abnormal



F. High Beam Indicator

When the headlight high beam is on, this indicator illuminates blue, and remains on



Display and Indicator

until the high beam is turned off.

G. Low Power Indicator

When the power of the battery pack is low (SOC < 20%), the low power indicator flashes. If the power is very low (SOC < 10%), the indicator stays on.



H. Ready Indicator

It indicates that the motorcycle is ready to move if the throttle is twisted.



I. ABS

(Anti-Lock Brake System) Indicator

The indicator illuminates or flashes when ABS system fails or is in the OFF mode. For description and operation, see "Starting and Operating" , on page 7.5.



4.4

4.3

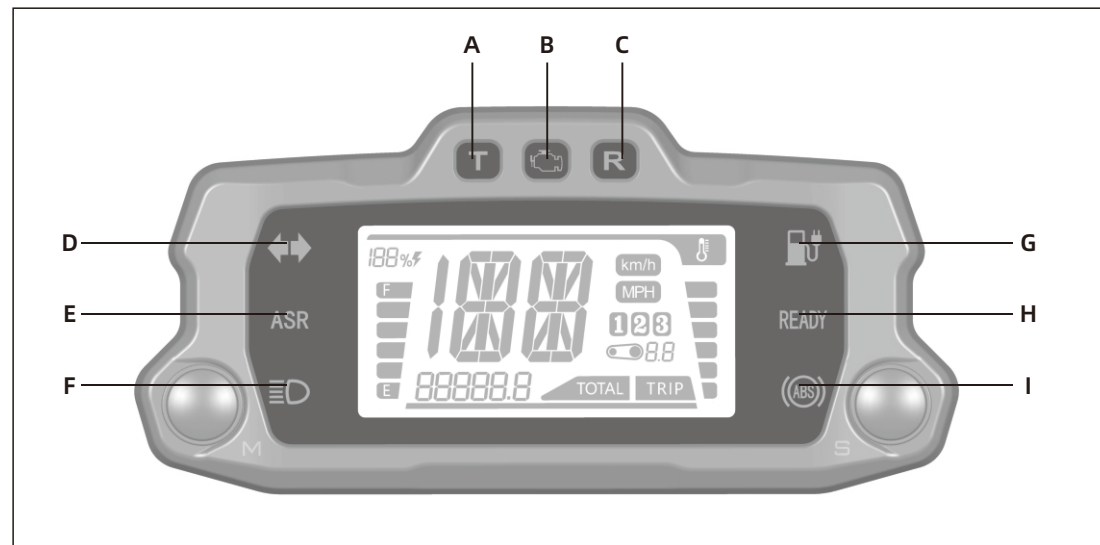

System Feature Setting

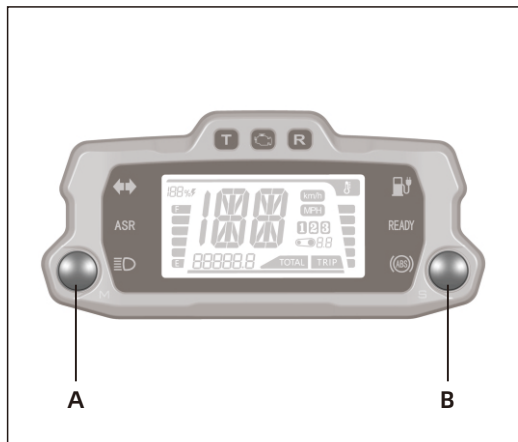

5.1

Dashboard Setting

The features and displays on the dashboard can be customized to your personal preferences by using the MODE and SEL buttons combined with the R\S button on the Handlebar Control

A. Mode Button (MODE)

By momentarily pressing or holding the MODE button you can reset fields and toggle through the trip menus and display options.

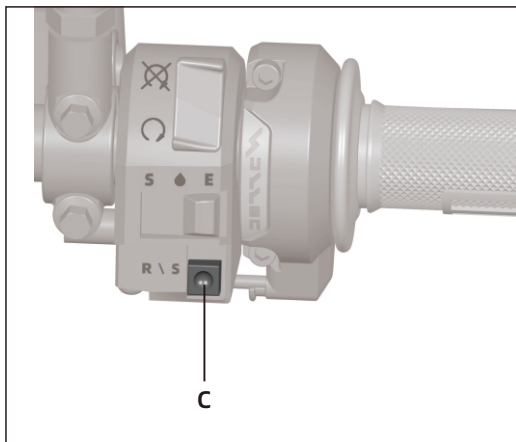

B. Select Button (SEL)

To select the corresponding feature by pressing SEL button when entering the feature menu.

C. Reverse mode\Switch setting button R\S

To set different feature by R\S button when entering the system feature mode. The R\S button can switch the ASR level during normal riding.

System Feature Setting

Display - Odometer

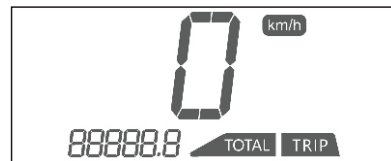

Select total or trip mileage:

1. To select the display of total or trip distances, momentarily press the MODE button when the dashboard in its normal operating mode and the speed is 0km/h.
2. Trip mileage and maximum speed are displayed synchronously. The speedometer displays the current speed during riding.
3. **TOTAL** is displayed in dashboard when selecting the total mileage.
4. **TRIP** is displayed in dashboard when selecting the trip mileage.

Select Miles per Hour (MPH) or Kilometer per Hour (km/h) :

1. Press and hold the MODE button with the dashboard off and turn the key switch ON whilst still holding the mode button for more than 2s with the

dashboard in its normal operating. Then select Miles per Hour (MPH) or Kilometer per Hour (km/h).



2. **MPH** is displayed when selecting Miles per Hour (MPH).
3. **km/h** is displayed when selecting Kilometer per Hour (km/h).

Display - Transmission ratio

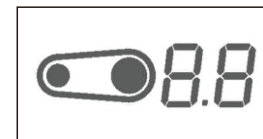

5.2

Transmission ratio setting: Press and hold the SEL button with the dashboard off and turn the key switch ON whilst still holding the SEL button for more than 2s with the dashboard in its normal operating. Then enter into the transmission ratio setting mode, and '8.8' flashes at a frequency of 1/sec. To adjust the transmission ratio by momentarily press MODE to decrease by 0.1, or SEL button to increase by 0.1. Press and hold SEL button for more than 2 seconds to save the current setting.

System Feature Setting

Example: The factory stock rear tire is 18-inch, factory configured rear sprocket is 52 gears, and factory configured front small sprocket is 14 gears.

Rear Wheel size (inch)	No. of Rear Sprocket teeth	Transmission ratio
19≥	52	0.9
18寸	52	1.0
18寸	≥57	1.1

5.3

System Feature Setting

System Feature Mode Display

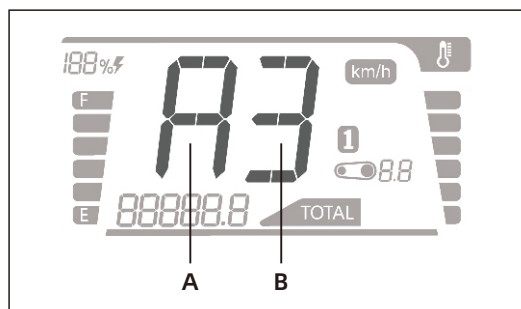

Note: Display one of the English letters in field A (Different English letters are displayed according to different feature modes)

Display one of the Numbers in field B (Different Numbers are displayed according to different feature modes)

System Feature Mode Setting:

MODE button and SEL button in dashboard: Press the two buttons at the same time to enter the system feature setting mode and the first feature (stay on) of the dashboard is displayed. Press and hold the R/S button in Right Handlebar Control to select X in the feature menu to exit the System Feature Mode, or exit automatically without any operation for 10 seconds.

Momentarily press R/S button in Right Handlebar Control: Cycle through the current menu

Press and hold R/S button in Right Handlebar Control: enter the setting menu of the currently selected feature menu or select the current setting and return to the feature menu

feature menu display mode: always on (display the setting for the current feature, and initially display BX when entering)

System Feature Setting

8、Exit System Feature Mode Setting (X)

setting menu display mode: flashing (display the setting for the current feature when entering)

The features are listed as follows:

- 1、Level setting of brake energy regenerative feature (B0 B1 B2 B3 B4 B5) Factory default at B2 (feature is disabled in B0, and strengthens in turn from B1 to B5)
- 2、Level setting of slide energy regenerative feature (E0 E1 E2 E3 E4 E5) Factory default at E3 (feature is disabled in E3, and strengthens in turn from E1 to E5)
- 3、Level setting of ASR feature (A1 A2 A3) Factory default at A2 (feature strengthens in turn from A1 to A3)
- 4、Setting of e-brake feature (P0 P1) Factory default at P1(feature is disabled in P0, and Activated in P1)
- 5、Setting of tilt protection feature (C0 C1) Factory default C1(feature is disabled in C0, and Activated in C1)
- 6、Beebox function (T0 T1) Factory default at T0 (feature is disabled in T0, and Activated in T1)
- 7、Reserved feature (F0 F1 F2) Factory default at F0 (feature is disabled in F0, and strengthens in turn from F1 to F2)

5.4

Warning
it is recommended to turn off the tilt protection in off road environment, to avoid the loss of power due to the triggering of tilt protection when performing some jump tricks.

Feature Introduction

Handlebar controls

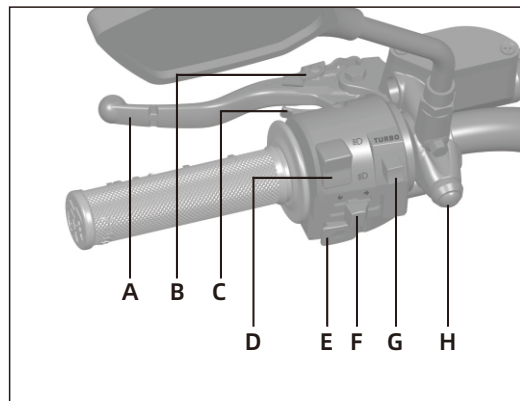

A. Rear brake Lever

When you pull the Lever backwards, it will control the rear brake system. When braking, the throttle should be in the idle position. The brake lights are also lit.

B. Parking brake

When parking on a slope, apply the locking brake to prevent the motorcycle from slipping. For instructions and operations, please refer to page 6.5 of "Feature Introduction"

C. Acceleration Slip Regulation switch (ASR switch)

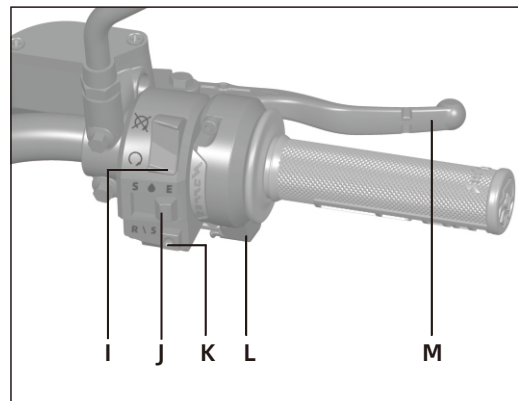

The Acceleration Slip Regulation (or called traction control) is set by the ASR switch in the left-hand handle switch and the R/S button of the right-hand handle switch, as the current motorcycle ASR setting.

(1) ASR switch: located behind the left-hand handle control, trigger switch.

① Regular no pressing: ASR off

② Regular long pressing: ASR is turned on and in the setted ASR value

③ Short press 3 times in a row: ASR is turned on, and

locked in current state; switching between active and disable. If you short press 3 times again, ASR will be turned off.

(2) ASR level setting key: also Switch setting button R/S, located in front of the right-hand handle switch, trigger switch. When the dashboard in the normal condition, the R/S button can switch between ASR setting level.

① Short press once: display the current ASR setting level

② quick short press twice: The ASR setting will be leveled up and display on the dashboard; keep press R/S button will made the ASR level cyclically between display A1~A3, please refer to page 5.4 for the specific setting method.

D. Headlight high/low beam switch

When the switch is pressed, the headlight changes from low beam to high beam. It remains in the selected position until it is switched back. When in the high beam position, the high beam indicator on the dashboard lights up

E. Horn button

When the Key switch is in the ON position, the horn will make a sound when the button is pressed. The

Feature Introduction

electric motorcycle is very quiet when riding, and the horn can be used to warn pedestrians or other motorists present.

F. Turn signals switch

When you push the Turn signals switch to the left or right, the corresponding front and rear Turn Signals will flash. When the Turn signals light switch is turned on, the Turn signals light is on.

Be sure to turn and other operations in accordance with the law. Unlike cars, turn Signals must always be manually cancelled on Sur-ron electric motorcycles.

Press the switch and it will return to the off position (middle).

G. Turbo Switch

The Turbo switch is the red button on the left handle switch. When the electric motorcycle is in the sport mode, press the Turbo switch and the electric motorcycle will instantly output the maximum power. The Turbo mode is only valid in the sport mode, follow " One full throttle, limited activate time, limited interval time" principle.

Specifically, When the motorcycle is in the sports mode and the electric motorcycle meets the operating conditions of Turbo mode, the Turbo mode indicator

Feature Introduction

on the dashboard will stay on. Press the Turbo mode switch and the Turbo mode is triggered, and the Turbo mode indicator on the dashboard will flashing slowly. When Turbo mode activated for a certain period of time (about 10 seconds), the Turbo mode indicator will flash rapidly, and the MCU will automatically exit Turbo mode after another 10 seconds, then the Turbo mode indicator goes out, and back to normal operation condition. It will take about another 10 seconds to reboot, and re-use the Turbo mode again.

6.3

H. ABS Switch

For operations and instructions, see " Starting and Operating" page 7.6.

I. motor stop switch

When the top 'A' of the switch is pressed, it will cut off the power supply for operation signal. The MCU remains in the state of no power output until the bottom 'B' of the switch is pressed. The switch does not close all operation electrical circuits, only the operating of the motor.

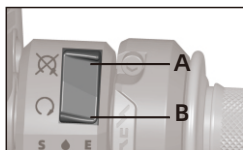

J. Riding mode button

For instructions and operations, please refer to page

6.4 of "Feature Introduction".

K. Reverse mode\Switch setting button R\S

For instructions and operations of the function setting, please refer to page 5.1 of "Function Setting".Reverse mode: When the throttle is in idle position and the electric motorcycle speed is 0km/h, press and hold the R/S function key and do not release it. The reverse indicator R on the dashboard will light up, and the electric motorcycle will enter the reverse mode. Twist the throttle and the motorcycle starts to reverse; once it enters the reverse mode, releasing the R/S button will instantly cut off the power. Only when the R/S button is released and the throttle is reset to zero will the reverse mode be exited and the forward gear mode will be functionally again.

L. Throttle control

Rotate the thottle handle counterclockwise to accelerate the motorcycle.

When the electric motorcycle is in the riding state, the kinetic energy regenerative system (KERS) will be activated when the ebrake is suddenly activated or the throttle position is back to idle. KERS will generate electric energy from the riding motorcycle

Feature Introduction

then stored in the battery pack, thereby helping to improve energy efficiency and increase the range. A slight resistance is felt when KERS is activated. The KERS level can be changed in the System Feature Mode, see page 5.4 for details.

M. Front brake handle

When you pull the handle backwards, it controls the front braking system. When braking, the acceleration handle should be in the idle position. The brake lights are also lit.

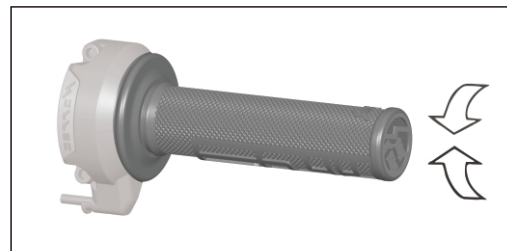

Riding mode button

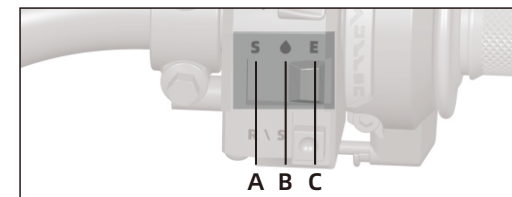

The Riding mode buttons include sports mode 'A', rain mode 'B' and ECO mode 'C'. You can switch between Riding mode while riding.

1. Sports mode 'A'

This mode has strongest power output and acceleration ability. It is highly recommended that users only use this mode after familiarizing themselves with the motorcycle.

2. Rain mode 'B'

In this mode, the power is reduced, and the ASR function is turned on and stay on by default, which can effectively prevent the motorcycle from slipping.

3. ECO mode 'C'

In this mode, the power and acceleration ability are much reduced, the electric motorcycle is much easier to ride and maximized the cruise range.

6.4

Feature Introduction

Your Storm Bee electric motorcycle is equipped with a parking system. When activated, the parking system will prevent the electric motorcycle from rolling forward or backward.

A. Parking system on

Pull the rear brake lever, push the parking brake lever into the gap between the brake lever and the brake lever housing, and release the rear brake lever.

B. Parking system off

Pull the rear brake lever, the parking brake lever will automatically pop out of the gap between the rear brake lever and the rear brake lever housing.

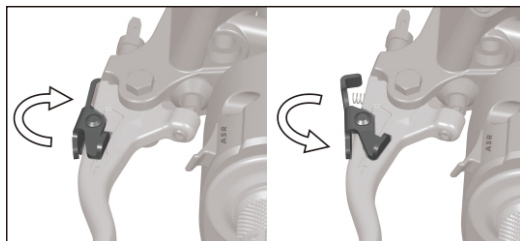

Battery pack removal

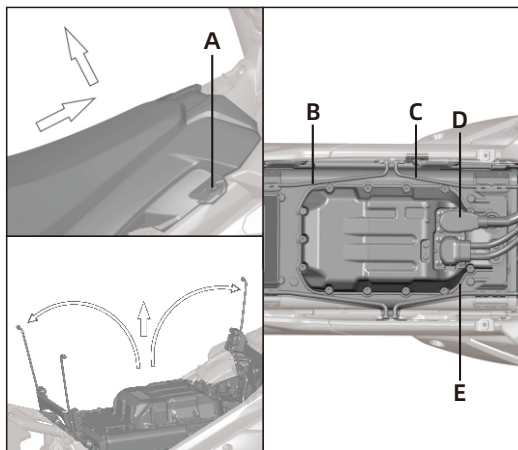

1. Use a portable tool to remove the two mounting screws of the front support cover of the seat
2. Push the seat and the front support cover of the seat forward first according to the arrow showing on the diagram, and then lift the seat upwards along the arrow.
3. First remove the charging plug 'D' and then remove the discharge plug 'E'
4. Remove the front compression bracket 'C' of the

Feature Introduction

battery pack and the rear compression bracket 'B' of the battery pack from the fixed lugs and rotate them to the corresponding positions according to the arrow showing on the diagram.

5. Lift the battery pack up to remove the battery pack and put in the safe position.

Battery pack installation

Battery pack installation

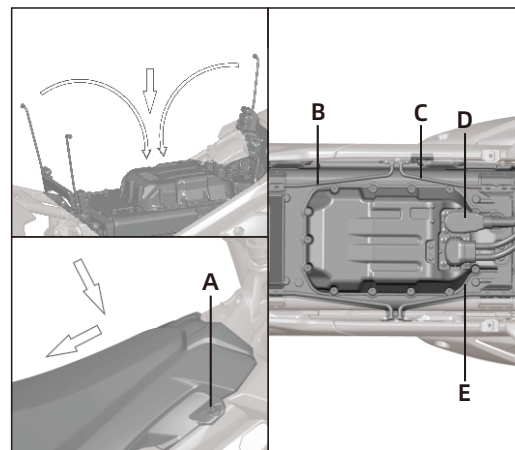

1. Put the battery pack in the battery compartment
2. Press the the front compression bracket 'C' of the battery pack and the rear compression bracket 'B' of the battery pack to the fixed lugs
3. plug the battery pack discharge plug 'E' back in first, then plug the charging plug 'D' next
4. Install the seat back in according to the arrow showing on the diagram, first put the the seat on the frame and push the seat backward along the arrow direction to fix the seat hook on the subframe.
5. Use a portable tool to install the two mounting screws of the front support cover of the seat 'A'

Warning

Before removal and installation of the battery pack on the electric motorcycle, the key switch must be in the OFF position, so that the whole motorcycle is in no power condition

Do not change the installation steps of the charging plug and the discharge plug at will. As the battery pack are high-voltage components, the wrong installation steps may cause serious injury.

Starting and Operating

Check before riding

Before operating the electric motorcycle, please check the following item to ensure that the electric motorcycle is in operational condition

Battery pack

Check that the battery level displayed on the battery pack or dashboard is sufficient to support your riding. We recommend you to full charge before use

Chain

Check the chain tension and condition. Adjust or replace if necessary. See "Chain" on page 10.12

Brake system

Pull the brake lever and push the motorcycle to see if the front and rear wheels are locked. You should be able to lock the wheels completely by braking

Throttle

When the key switch is in the off position, twist the throttle and release it to check whether the throttle is move smoothly and return to idle freely.

Tyre

Check the tire pressure and tread depth of the tires.

Check the cold tire pressure, maintain the correct tire pressure, and check for damage and abnormal wear

of the tire. As described on page 10.8, when the tread depth is less than 2 mm, please replace the tire immediately.

Warning

Unusual tire pressure is a common reason that cause of tire failure, and may cause severe tires issues or loss the control of the electric motorcycle, which may result in serious personal injury. Check the tires regularly to ensure proper tire condition.

Electrical System

Check whether the headlights, turn signals lights and brake lights/taillights are functioning properly

Cooling liquid

Check the cooling liquid level, refill or change when needed. please refer to page 10.8 of "Liquid cooling system".

Starting and Operating

Key Switch // Steering lock

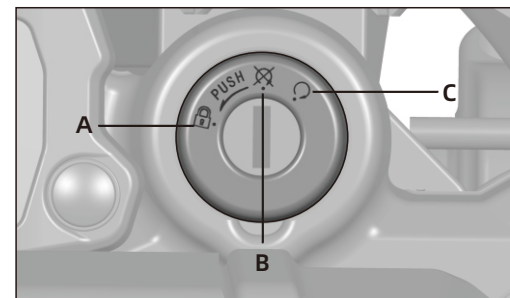

This is a three-position key switch located above the front fork and in front of the handlebar. The switch positions are as follows (the off-road version equipped a two-position switch):

1. steering lock 'A' (off-road version does not have this function)
2. OFF 'B'
3. ON 'C'

The key should be removed from the electric motorcycle when parking to prevent motorcycle been stolen. The key can be removed in the OFF or steering lock position.

Steering lock

Using a steering lock when parking can prevent unauthorized use and help prevent motorcycle been stolen.

Operating the Steering lock:

1. Rotate the handlebar to the extreme left position.
2. With the key in the OFF position, press the key downward and then turn the key counterclockwise to the lock position.
3. Remove the key.

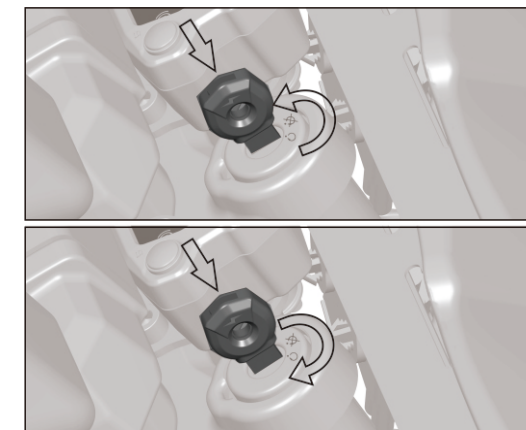

Starting and Operating

Unlock the steering lock:

1. Insert the key, press down and turn clockwise.

OFF position

This position is used to turn off the Storm Bee electric motorcycle, thereby disable all the electrical system.

ON position

This position is used to operate the Stormbee electric motorcycle. The following visible instruments will light on when you turn the key switch ON:

Headlights turns on

Dashboard display turns on

Riding a Storm Bee electric motorcycle

This section gives you a general idea of how to operate the electric motorcycle safely

Starting

1. Turn the key switch to the ON position.
2. Confirm the battery percentage display on the dashboard.
3. Press the motor stop switch to the start position.
4. Gently squeeze the left brake lever to make sure

that the parking brake is unlocked.

After confirming that there are no obstacles and passing vehicles in the surrounding area, retract the sidestand, gently squeeze the brake lever to enter the READY mode, and the green READY light on the dashboard will light up, and twist throttle inward (counter clockwise) to increase the speed; when the throttle is rotated outwards, the motorcycle speed decreases.

Braking

The brake levers are located on the left and right handlebars

When you pull the right brake lever, it controls the front brake.

When you pull the left brake lever, it controls the rear brake.

Warning

If ABS is disabled or cannot be operated, apply too much force to the brakes which will cause the wheels to lock up. This may cause you to lose control of the electric motorcycle and may result in serious injury or death. Progressive use of the brakes and control of the

Starting and Operating

structure, but high-power density, light weight design and easy maintenance advantage. Long-term continuous operation at high power/high speed will result in high temperature of the power system.

Therefore, your Storm Bee electric motorcycle will self-monitoring the temperature of each component of the power system to ensure the power system operating through a comprehensive multiple thermal management strategy.

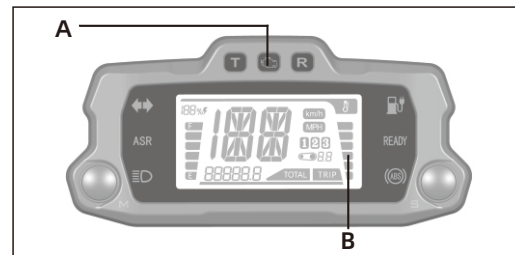

Temperature indicator on the dashboard 'B'

The indicator had two information states:

In Phase 1, when riding the electric motorcycle, the temperature indicator progress bar will gradually increase until the entire temperature indicator 'B' flashes, and the orange system warning indicator 'A' above the dashboard will also start flashing, and tell

operating force on the brake lever will gradually stop the electric motorcycle without locking the wheels. Your electric motorcycle is a powerful vehicle, so it is strongly recommended that you practice adequately, and familiar with all the safe emergency stop operation.

Park the Storm Bee electric motorcycle

1. When the throttle is in the closed position, press the motor switch to the closed position. The switch can also be used to turn off the motor in an emergency.
2. Turn the key switch to the OFF position and remove the key, and keep it in a safe place.
3. Lock the parking brake to prevent the motorcycle from moving due to the gradient (it is recommended to use the parking brake when parking on flat ground and slope, this is a good parking habit).
4. After each ride, please check the power and charge the battery pack in time.

Temperature indicator

The air-cooled electric power system of the Storm Bee electric motorcycle has a simple and reliable

Starting and Operating

you the Storm electric motorcycle is about to enter the temperature protection mode. To prevent the motorcycle from forced reducing its power, you can choose to slow down and riding smoothly or switch to ECO mode until the indicator light stops flashing.

Phase 2、If the temperature continues to rise, the orange system warning indicator 'A' above the dashboard will stay on to inform you that the electric motorcycle is now enter a temperature protection strategy, and the power of the Storm Bee electric motorcycle will be reduced accordingly.

ABS (Anti-lock braking system)

Warning

The ABS anti-lock braking system maximizes the braking efficiency in emergency situations and the safety during riding. Under certain conditions, ABS can shorten the braking distance, but it cannot replace good riding habits.

Warning

Please ride safely and respect the legal speed limit on the road.

Warning

Ride cautiously when turning. If you braking while turning, ABS may not be able to offset the centrifugal force of inertia. Such activities will cause unsafe riding and easily cause accidents. Certain riding conditions and environments may reduce the braking efficiency of ABS and make its braking distance equal to that of a motorcycle without ABS.

1、ABS Switching ON/OFF conditions

- ① The whole motorcycle is powered on
- ② The speed of the front and rear wheels of the motorcycle is zero
- ③ The electric motorcycle is in non-diagnostic mode

2、ABS operation method

- ① After turn the Key switched ON, ABS is turned on by default
- ② When the ABS is in the OFF condition, the ABS indicator flashes at a frequency of 1.2 second, when the ABS is in the ON condition, the ABS indicator is off
- ③ When the ABS switch is pressed for more than 3s

and not released within 5s, the ABS ON/OFF switch request will be ignored and the ABS keeps the current state; When the ABS switch is pressed for more than 30s, the ECU of the ABS regards the switch signal as a fault signal, and the ABS returns to default ON state. The ABS can only be turned OFF after the power is switched on again.

Disable ABS

1. In the parking state, put down the sidestand
2. Place the motor stop switch in the OFF position
3. Turn the key switch to the ON position
4. Press and hold the ABS switch for 3 seconds and then release, the rear wheels ABS function is now turned off, and the ABS indicator light flashes at a frequency of 0.2 second; Then press and hold the ABS switch again for 3 seconds and release it, and the ABS function will switch back to ON state; press and hold the ABS switch again for 3 seconds, now all ABS functions are turned OFF, and the ABS warning light flashes at a frequency of 1.2 second.

Warning

When ABS is disabled, the electric motorcycle will be able to operate as a motorcycle without ABS function.

Starting and Operating

and the braking distance may increase

Caution

When the ABS system is disabled, the ABS indicator will continue to flash (1.2 second a time).

ABS indicator

1. When the ABS system detects a fault, the ABS fault indicator will light up. If the fault is eliminated, the ABS warning light will disappear when the motorcycle speed reaches 5km/h in the current states or turn ON the key switch and reaches the speed of 5km/h next time;
2. When the ABS is in the ON mode and the speed of your electric motorcycle reaches 5km/h, the ABS indicator light goes out,
3. When the ABS is in the off mode, the ABS warning light flashes at a frequency of 1.2 time/sec;
4. When the ABS switch is pressed, the ABS warning light flashes at a frequency of 1.2 times/sec, but when the ABS switch is pressed for more than 30s, the ABS warning light is always on;
5. When the ABS is in the diagnosis mode, the ABS warning light is on

Starting and Operating

Warning

When your Storm Bee electric motorcycle exceeds 5km/h, if the ABS indicator light is still on, it indicates that the ABS system is malfunctioning, and the ABS may not work normally. Please contact the authorized dealer or manufacturer for after-sales repair in time. When the ABS system does not work, your Stormbee electric motorcycle will operate as a motorcycle without ABS, which may increase the braking distance and may cause unpredictable conditions.

ABS work requires comparing the relative speed of the front and rear wheels. Failure to use the tires specified by the manufacturer may adversely affect the ABS function and the braking distance of the Stormbee electric motorcycle

If the speed of the front and rear wheels changes greatly, such as during a wheel lock up or off-road riding, the ABS indicator will light up and ABS will be disabled.

Caution

To reactivate the ABS, please stop the Storm Bee electric motorcycle completely, then turn the key switch key to the off position, wait for about 5s, and then return it to

the ON position. Once both wheels reach 5km/h and are fully functional, the ABS light should go out

Front fork adjustment

Compression damping—FASTACE、KKE

Use a flat-blade screwdriver to turn the screws 'A' on the top of the left and right front fork to adjust the compression damping. The symbol "+" means hard (large compression damping), and the symbol "-" means soft (small compression damping).

Turn the adjusting screw 'A' clockwise in the "+" direction to increase the compression damping.

Turn the adjusting screw 'A' counterclockwise in the "-" direction to reduce the compression damping.

Caution

Try to keep the damping adjustment balanced.

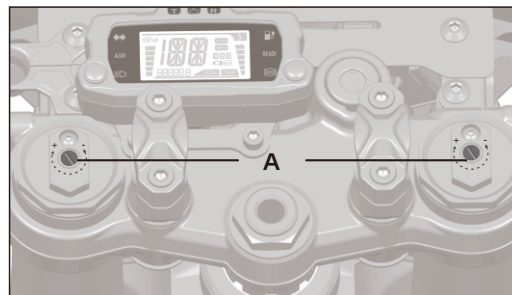

Caution

The appearance of front fork in different brands may be different, please refer to the actual product.

Rebound/damping FASTACE//KKE

Adjust the rebound damping by turning the screws 'B' at the bottom of the left and right front fork with a flat-blade screwdriver. The symbol "+" means hard (slower rebound), and the symbol "-" means softer (faster rebound).

Turn the rebound adjusting screw 'B' clockwise in the "+" direction to reduce the rebound speed.

Turn the rebound adjusting screw 'B' counterclockwise

Starting and Operating

in the "-" direction to increase the rebound speed.

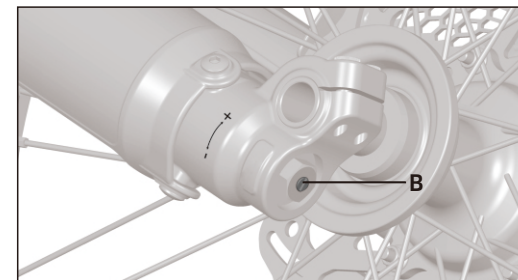

Caution

The appearance of front fork in different brands may be different, please refer to the actual product.

The damping and spring preload should be adjusted reasonably according to the road conditions and the weight of the rider. Avoid adjusting the damping to the maximum limit value, otherwise the front fork may malfunction or even cause a crash.

Starting and Operating

Rear shock adjustment

Compression adjustment—FASTACE、KKE

The compression adjustment screw is located on the top right side of the rear shock absorber. "+" is printed on the adjusting screw to indicate hard (large compression damping) and "-" indicates soft (small compression damping).

Turn the adjusting screw 'A' clockwise in the "+" direction to increase the compression damping.

Turn the adjusting screw 'A' counterclockwise in the "-" direction to reduce the compression damping.

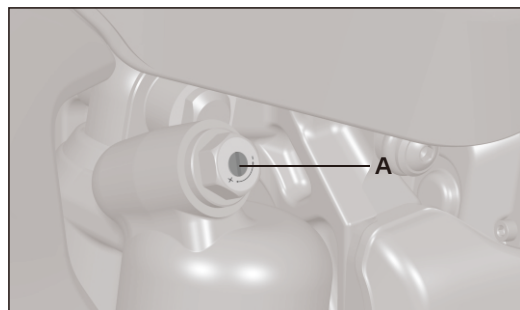

Note: The appearance of rear shock absorber in different brands may be different, please refer to the actual product.

Rebound adjustment—FASTACE、KKE

The rebound adjustment screw 'B' is located at the bottom of the rear shock absorber. "+" printed on the adjustment screw means hard (slower rebound), "-" means soft (faster rebound)

Turn the rebound adjusting screw 'B' clockwise in the "+" direction to reduce the rebound speed.

Turn the rebound adjusting screw 'B' counterclockwise in the "-" direction to increase the rebound speed.

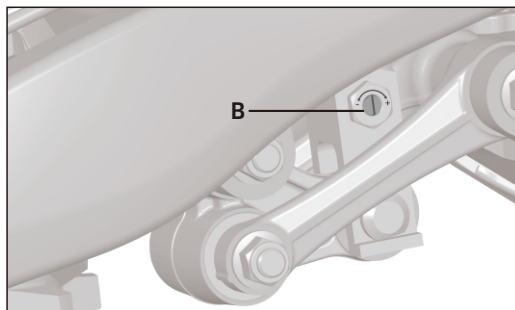

Note: The appearance of rear shock absorber in different brands may be different, please refer to the actual product.

Power management

Battery pack

The Storm Bee Motorcycle uses high-performance high rated lithium battery which can be used in the ambient temperature range of -20°C~50°C, the best working condition is when ambient temperature is between 10°C~30°C. Too low or too high ambient temperature will affect the battery pack performance and service life. warning Do not use it at temperatures beyond the allowable range, and do not charge the battery pack below 0°C.

The charge time of the battery pack is about 4h at normal ambient temperature.

When the ambient temperature is too low, the performance of the battery pack will be affected. It is normal to reduce the range a little, and the performance of the battery pack will automatically recover after the temperature rises back to working condition.

When battery pack not in use for a long time, please charge the battery percentage to about 60%~80%, and you will need to check the remaining battery percentage every month. If the battery percentage drops below 30%, it must be recharged to 60% ~ 80%.

It is strictly forbidden to wash the battery pack with a

Rear shock preload adjustment—FASTACE、KKE

1. Loosen the spring lock ring 'A'.

2. Use an adjusting wrench to turn the adjusting ring 'B'.

3. Rotate the adjusting ring 'B' counterclockwise to reduce the preload on the spring and rotate the adjusting ring 'B' clockwise to increase the preload of the spring.

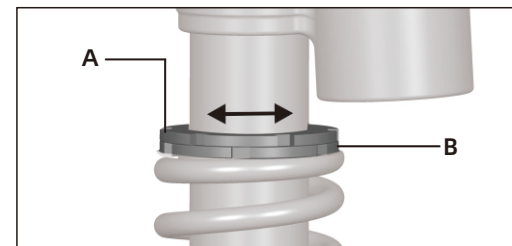

Note: The appearance of rear shock absorber in different brands may be different, please refer to the actual product.

Note: The damping and spring preload should be adjusted reasonably according to the road conditions and the weight of the rider. Avoid adjusting the damping to the maximum limit value, otherwise the shock absorber may malfunction or even cause a crash.

Power management

high-pressure water pump, let alone immerse the battery pack in water. The wading of the whole motorcycle should not exceed the center of the wheel, otherwise it may cause water ingress in the battery pack, internal short circuit and permanent failure of the battery pack.

If water ingressed in to battery pack or battery pack had other issues, it is strictly forbidden to charge the whole motorcycle or battery pack again. It may cause the risk of fire, combustion and explosion of the battery pack.

The battery pack is water resistant and sealed with a high voltage circuit inside. If the external structure is damaged this will reduce the water-resistant performance of the battery pack. If the water-resistant structure is damaged, please contact the after-sales service. It is strictly forbidden for customers to disassemble the battery pack, to avoid potential damage and serious danger.

Power supply and charging

Before charging, please check whether the input voltage range of the charger is consistent with the grid voltage, AC 95 ~ 125V / 190 ~ 250V.

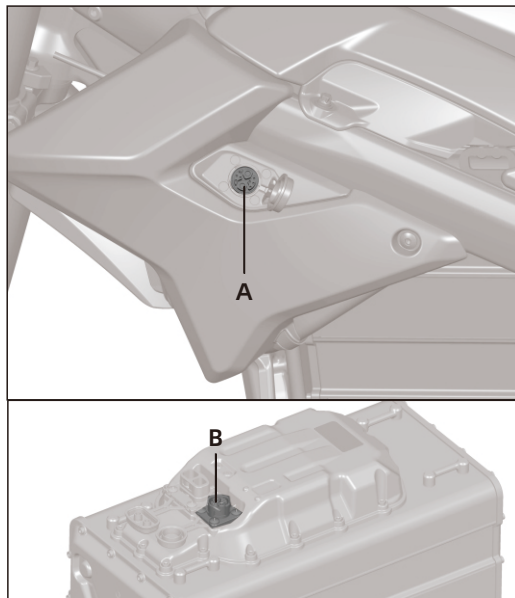

Before charging, please check whether the load power of AC power network socket can meet the power requirements of charger.

When charging, please connect the battery pack first, and then connect the AC power input plug. If you plug in the AC power first and then connect to

the motorcycle battery pack, the charger can not charge normally.

You can directly plug the charger into the battery charging port 'A' on the portside of the motorcycle or plug the charger into the charging socket B of the removed battery pack to charge.

The charger will turn off automatically when it is fully charged. Please disconnect the power supply of the charger and unplug the charging plug.

When charging, please put it in a safe place beyond reach of children.

Avoid using the battery pack when it has just reached full charge. It is recommended to let it cool down for 10 minutes or longer after it is fully charged.

It is forbidden to cover any object when charging. This charger is for indoor use. Please use it in a dry and well ventilated environment.

After charging, please put the rubber cap of charging socket back on.

Power management

Warning

- 1. Always charge the battery pack in a well-ventilated place away from any fire hazard. If you want to charge the electric motorcycle outdoors, do not charging in the rain or humidity condition.**
- 2. The battery pack can only be charged with a special charger supplied with the original motorcycle manufacturer or specified by the manufacturer. The use of unauthorized chargers or accessories may cause damage or failure of the battery pack, or even cause danger.**
- 3. Do not charge the battery pack below 0 °C, otherwise it will damage the battery pack. It can only be charge after the temperature of the battery pack rises back to above 0 °C. The maximum allowable charging temperature inside the battery pack is 60 °C. If the internal temperature of the battery pack exceeds this temperature, it can only be charged after cooling to below 60 °C. If the battery pack is discharged rapidly due to heavy duty riding, the internal temperature of the battery pack may still be higher than 60 °C even if the ambient temperature is low.**
- 4. The battery pack is only allowed to return to normal temperature by itself. Do not use other methods to raise**

or lower the temperature of the battery pack.

5. The battery pack may not be able to charge immediately after high power output or high temperature operation. The battery pack should cool down for 30 minutes or longer before charging. The battery management policy does not allow charging when the internal temperature is high, otherwise the battery life will be shortened.

-----_Serious warning_-----

When you find the following situations, please stop charging immediately, disconnect the power supply, and do not use the electric motorcycle. Contact the after-sales service or send it to the maintenance Office for maintenance as soon as possible.

1. The appearance of the battery pack is damaged.
2. Strange smell during charging.
3. The temperature of the battery pack or charger is too high and unable to cooling down by itself.
4. Charging can not be complete for a long time.
5. If the battery pack is on fire, please put the battery pack into the water immediately to prevent more damage

power system////

The Storm Bee Electric Motorcycle power system include MCU, motor and a reduction gearbox.

-----_Warning_-----

1. Motor is designed to be sealed and water resistant. The customer is not allowed to disassemble the motor without permission, otherwise may cause the position sensor malfunction or damage the corresponding seal which can lead to motor malfunction.
2. here is gear oil inside the reduction gearbox. Please ensure that the gear oil level is in recommended position during the operation. Users are not allowed to disassemble the reduction gearbox without permission.
3. The MCU is a precision high voltage electronic component. Incorrect wiring may cause damage to the MCU. Do not disassemble the MCU and cable without permission, otherwise it will cause electric shock, burn and other serious accidents.
4. The power system of the Storm Bee Electric Motorcycle must be repaired or replaced by a professional technician authorized by the manufacturer. Users are not allowed to disassemble and modified the power system of the Storm Bee Electric Motorcycle without permission.

Terminal box////

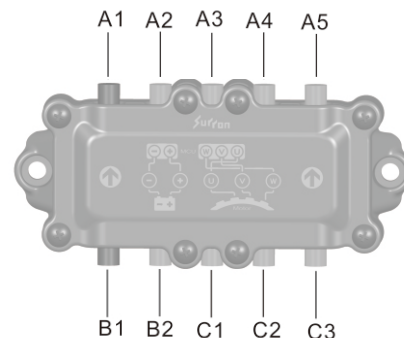

- A1 (black) -----MCU negative terminal
- A2 (red) -----MCU positive terminal
- A3 (yellow) -----MCU phase U terminal
- A4 (green) -----MCU phase V terminal
- A5 (blue) -----MCU phase W terminal
- B1 (blac) -----negative power terminal
- B2 (red) -----positive power terminal
- C1 (yellow) -----motor phase U terminal
- C2 (green) -----motor phase V terminal
- C3 (blue) -----motor phase W terminal

-----_Warning_-----

1. Power cables had high current during operation, do make sure the cables are correctly and firmly connected, ensure that the torque and tightness of cable fastening bolts meet the recommended torque requirements and cable insulation also meet the requirements. Do not disassemble the power cable without any permission.
2. The power system is 90V high voltage system and the power cable is in orange colour. No matter the motorcycle is in operation, repair and maintenance or cleaning, it is necessary to ensure that the electric motorcycle is well isolated.

Maintaining Your Motorcycle

Maintenance Item

The following table lists the brake fluid, Reduction gearbox oil and coolant to be maintained and replaced.

Lubricants	Oil type	volume
Braking fluid	DOT4	\
Reduction gearbox oil	10W-40 SG or higher	300ml
Coolant	Ethylene glycol(-40°C)	160ml

Maintenance Records

Follow the maintenance schedules on page 10.2. After each scheduled service or routine is performed, record the information in the Maintenance Record chapter of this manual.

Regular Maintenance

Keeping your electric motorcycle well maintained is absolutely essential to your safety. It's also a good way to get maximum performance of Storm Bee, avoid breakdowns, and have much more fun. The required maintenance schedule that follows, specifies how often you should have your electric motorcycle serviced and what items need attention.

If you do not feel capable of performing a given task or need assistance, remember that your dealer knows your electric motorcycle best and is fully equipped to maintain and repair it. Your warranty will be void if damage, malfunctions, or performance problems caused by the improper maintenance or repair of the electric motorcycle, installation of any parts or accessories not sold or approved by manufacturer.

The service intervals in this maintenance schedule are based on average riding conditions. Some items will need more frequent service if you ride in unusually wet or dusty areas. Consult your dealer for recommendations applicable to your individual needs and use. It is recommended that you maintain your electric motorcycle at least once every 6 months by an authorised dealer, regardless of the distance traveled.

Maintenance Schedule

To maintain the safety and reliability of your motorcycle, regular inspection and service is required as shown in the Maintenance Schedule that follows. The initial maintenance is vitally important and must not be neglected. Where time and mileage are listed, follow the interval that occurs first.

Maintaining Your Motorcycle

Storm Bee Motorcycle Maintenance Schedule						
Check item	every ride	Initial100km	500km	2000km	5000km	10000km/12months
Tyre (Front and rear)	●					
Brake system (front and rear)		●	●	●	●/↻	●/↻
Drive chain		●	●💧	●💧	●/↻	●/↻
Battery voltage	●					
Dashboard Warning Code	●					
Reduction gearbox oil		●		●		●/↻
Front fork and rear shock		●		●		●/🔧
Brake fluid		●		●		●/↻
Coolant	●	Check every 3000km				↻
Bearing		●		●	●	●/↻
Bearing	●					
wheel spoke	●	↻			↻	↻

check
 lubrication
 replace
 adjustment
 maintenance

Maintaining Your Motorcycle

Torque management

Check regularly and tighten the following fasteners on the Storm Bee Motorcycle according to the specified torque

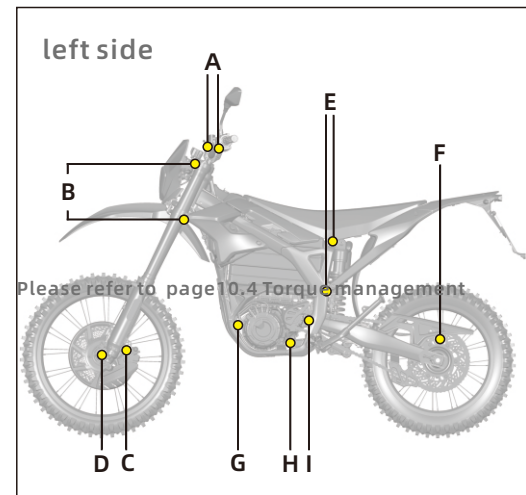

Please refer to page 10.4 Torque management

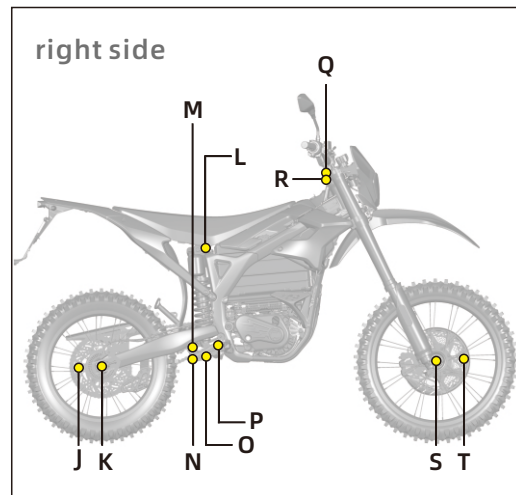

Maintaining Your Motorcycle

	item	torque	specifications	instructions
A	Handle bar mount screws	30N.m	Hexagon socket M8*20	\
B	Front fork mounting bolts	28N.m	Hexagon socket M8*40	\
C	Front brake caliper mounting bolts	30N.m	Hexagon socket M8*35	\
D	Front axle bolts	55N.m	Hexagon flangebolts -M14*1.5*20	\
E	Subframe mounting screws	28N.m	Hexagon socket pan headstep screws M8*30	Threadlocker needed (eg. KAFUTER K-0609 or similar products)
F	Rear sprocket mounting screws	28N.m	Hexagon socket countersunk M8*25	Threadlocker needed (eg. KAFUTER K-0609 or similar products)
G	Motor Installation Axle Front	55N.m	Hexagon flange bolts M10*72	\
H	Motor Installation Axle Rear	55N.m	Hexagon flange bolts M10*108	\
I	Swingarm Pivot	130N.m	T-Shaft - Thread M16*1.5	\
J	Rear brake pads install screws	10N.m	Hexagon socket countersunk -M6*25	Threadlocker needed (eg. KAFUTER K-0609 or similar products)
K	Rear Wheel axle nut	160N.m	Hexagon self-lock nut M22*1.5	\
L	Rear Shock Axle TOP	55N.m	Thread length M10*1.25-16	\
M	Triangular Centilever Axle TOP	85N.m	Hexagon flange bolts M12*1.25-110	\
N	Triangular Centilever Axle BOTTOM	85N.m	Hexagon flange bolts -M12*1.25-95	\
O	Rear Shock Axle BOTTOM	55N.m	Thread length M10*1.25-14	\
P	Link Rod Axle	85N.m	Hexagon flange bolts M12*1.25-136	\
Q	Triple Clamp Bolt TOP	65N.m	M26*8	\
R	Steering Head Nut	20N.m	M30*8	\
S	Front Wheel axle nut	28N.m	Hexagon socket -M8*30	\
T	Front brake pads mounting screws	10N.m	Hexagon socket countersunk -M6*25	Threadlocker needed (eg. KAFUTER K-0609 or similar products)

Battery pack

Caution

1. **Battery packs are lithium-ion systems that do not require maintenance but need to be recharged from time to time. When not in use for a long time, please charge the battery pack to about 60% ~ 80% of the power storage. You will need to check the remaining power every 1 month. If the battery pack power drops below 30%, it should be recharged to 60% ~ 80%.**
2. **The battery pack should be kept away from high temperature environments. Do not store it in high temperature environment or under direct sunlight. When not used for a long time, please store the battery pack in an ambient temperature of 10°C ~ 30°C.**
3. **Only a service agent authorized by the manufacturer can be qualified to repair or dismantle the battery pack.**
4. **Dispose of used battery packs please according to your local laws. The battery pack is encouraged to be recycled and not discarded at will.**

Brake system

This chapter introduce how to maintain Storm Bee motorcycle brake system. Which covers ABS (anti-

lock braking system), brake pads (front and rear dedicated brake pads) and recommends brake fluid volume and types for front and rear brake systems.

Brake system HCU

Only when the HCU (hydraulic control unit) is filled with brake fluid can the braking system operate efficiently. To fill the HCU with brake fluid, a vacuum pump and a filling machine are needed. Users need to bleed air from the HCU. This should be taken to the designated authorized dealer for the work to be carried out.

Brake fluid level check

Brake oil cup

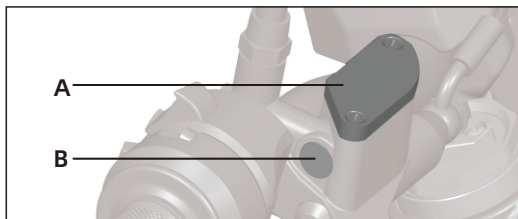

Check through the oil level inspection window 'B' to observe the level of brake fluid. If the fluid level is significantly lower than one-third of the oil mirror, brake fluid must be added. Before opening the oil

cup, please clean all dust or debris on the lid 'A'.

A low fluid level may indicate worn brake pads or a leak in the hydraulic system. Check whether the brake pads are worn and/or the hydraulic system is leaking. Only use the new DOT 4 brake fluid in a sealed container.

The steps to add brake fluid are as follows:

1. Unscrew the two screws on the upper cover of the oil cup, remove the upper cover of the oil cup and the oil cup gasket.
2. Add new DOT 4 brake fluid.
3. Check the lid seal to make sure that there is no wear or damage, and the position is correct.
4. Install the upper cover screw of the oil cup (torque 4N.m).

Warning

Before checking the liquid level, the Storm Bee electric motorcycle should be in a flat and upright state and the handlebars should be turned back to ensure that the oil cup is in a horizontal position.
When adding new brake fluid, if the brake fluid overflows, it should be removed immediately to prevent contamination of other parts.

Caution

Do not splash the brake fluid on the painted surface, it may damage the painted surface. Spilling brake fluid on plastic products can cause it to corrode. Before removing the cover, be sure to put an oil absorbent towel under the main cylinder reservoir.

Brake disc inspection

The thickness of the brake disc should be checked regularly. The minimum thickness is 3.0mm

Brake pad inspection

The brake pads must be checked at the specified intervals in the maintenance scheduled, please refer to page 10.2. Check the remaining amount of brake pad material visually from the side of the brake caliper. If the thickness of the front brake pad is less than 1.5mm and the thickness of the rear brake pad is less than 1mm, replace the brake pads. If the metal part of the brake pad 'A' is damaged, please replace the two brake pads immediately.

Brake pad replacement

It is recommended to check and run-in after replacing new brake pads or brake discs to ensure

Maintaining Your Motorcycle

that the brake discs and brake pads adapt and match again. Correct running-in can improve the brake feel and reduce or eliminate brake noise.

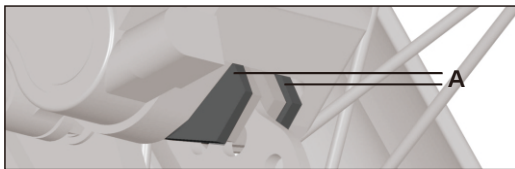

Front brake pad



Rear brake pad

Warning

When using a new brake system or new brake pads, the initial braking force may be too small. Please try to run-in the brake pads and brake discs at low speed and safety to ensure that the brake system provides normal braking force.

Parking brake

The Storm Bee electric motorcycle is equipped with a parking brake. When the rear brake lever (located on the rear brake handle) is in the depressed position, it

should be able to lock the rear wheels. Please check the parking brake regularly.

Parking brake inspection

1. Raise the Storm Bee electric motorcycle on the support bench to make the rear wheel off the ground.
2. Firmly hold the rear brake handle and hold it.
3. Push the rear brake parking paddle firmly into the parking position until it can no longer be pushed.
4. Release the rear brake handle, and then release the parking brake paddles.
5. Turning the rear wheel feels obvious resistance that cannot be turned, and the motorcycle can be parked normally at this time.

Note

Do not adjust the push rod adjustment screw on the handle at will, because this will cause the oil circuit to fail to refill normally after the brake is worn out.

Warning

If the parking brake cannot effectively lock the rear wheels, please contact an authorized dealer or after-sales service in time.

Liquid cooling system

The motorcycle has a liquid cooling system, please check and maintain according to the contents below

Warning

Do not open the lid of the liquid cooling system tank when the water pump and fan is operating. Coolant is toxic and can cause personal injury or death. If any personal taken coolant by accident, please seek medical help immediately. Please avoid excessive inhalation of coolant steam. If you accidentally inhale too much, please ventilate and breathe fresh air immediately; if the coolant gets into your eyes, immediately rinse with clean water and seek medical attention. Wash hands and soiled clothing thoroughly after servicing the vehicle. Keep children and pets away from coolant.

Note

The coolant will corrode the surface painting of the vehicle. When maintain the vehicle, pay attention to protect the surface painted parts and well protected those parts. If it is contaminated, please wipe the coolant clean in time.
Do not use other liquids instead of special coolants. If

Maintaining Your Motorcycle

already use other liquids instead, the liquid cooling system may be damaged, thereby reducing the working efficiency of the liquid cooling system, and the liquid cooling system may not be protected against frost and corrosion.

Add coolant

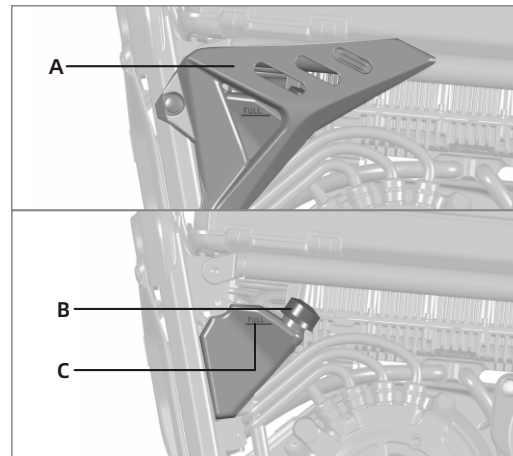

1. Support the vehicle with the side stand.
2. Please remove the left MCU Cover A of the

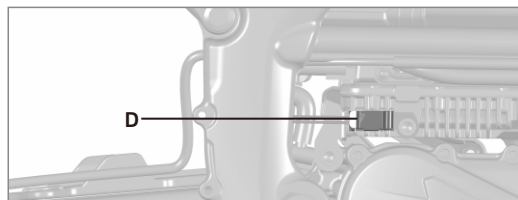

controller and open the tank lid B, and add the coolant to the mark line C of the highest liquid level.

3. Turn on the key switch and start the liquid cooling system as follow:

a. Use about 1Liter of warm water (please be extremely careful not to casue damage on skin), slowly pour it on the temperature sensor D, until the liquid cooling system starts to work.

b. Use a hair dryer to turn on the high temperature gear to centrally heat the temperature sensor D (need to isolate the surrounding cables) until the liquid cooling system starts to work

4. Continue to fill the tank with the remaining coolant while the liquid cooling system is running.

5. Turn OFF the key switch and wait for 30 seconds before observing the liquid level position. The coolant should be above the mark line C of the highest liquid level.

6. Install the tank lid B and MCU Cover A back on.

Check coolant level

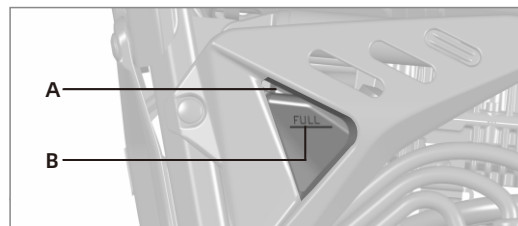

coolant level ckeck steps are as follows:

1. Support the vehicle with the side stand when liquid cooling system is inactivated.

2. Check the position of the coolant level through the observation window A. At this time, the coolant level should be above the marking line B of the highest level of the tank.

3. If the coolant level not reach the marking line B, please add the coolant in time. Check above for the filling procedure.

Change the coolant

The coolant must be checked and replaced according to the times specified in the maintenance schedule

table on page 10.2. Please contact your delaer and ask them to change coolant for you.

Reduction Gearbox

The inspection and maintenance of the Reduction gearbox should be carried out at the times specified in the maintenance schedule table on page 10.2.

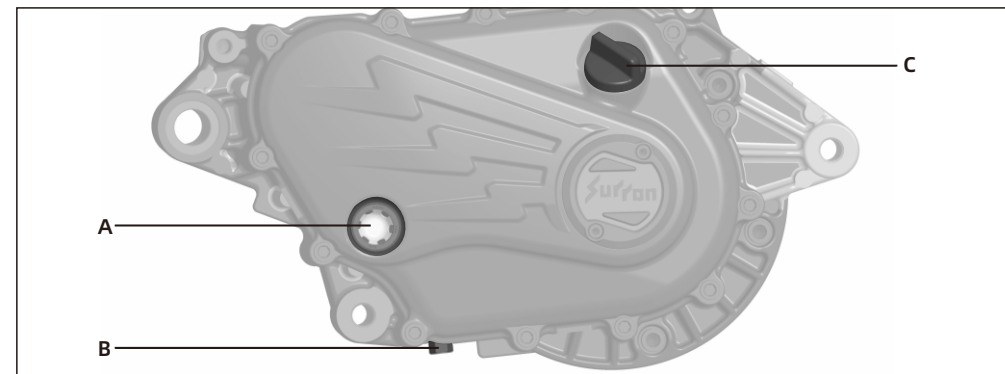

Inspection and replacement of Reduction gearbox oil

1. Support the vehicle upright and stand on the level ground when liquid cooling system is inactivated, observe the oil mirror A on the reduction gearbox, the normal liquid level should within the range of 1/2 to 2/3 of the mirror.

2. When replacing the gearbox oil, make sure turn off the key switch, and then open the oil drain bolt B to

release the oil from the oil drain port until it drips discontinuously, then screw the bolt back in and tighten the oil drain bolt B

3. Add new gear box oil from filling port C to make the liquid level reach 1/2 to 2/3 of the normal range of oil mirror A (about 300ml).

Maintaining Your Motorcycle

Suspension system

1. It is recommended to clean the surface of the shock absorber immediately after each ride, especially the mud and sand attached to the surface of the main tube. When cleaning with a high-pressure water gun, it is strictly forbidden to flush upwards facing the dust-proof seal lip, as this will flush mud and sand into the oil seal lip and cause wear and oil leakage.

2. Do not use flammable or corrosive solvents to clean otherwise it will cause damage to the dust-proof oil seal. It is recommended to use a neutral detergent and a soft cotton cloth to assist in cleaning.

3. It is recommended to apply a layer of lubricating grease on the surface of the main pipe after cleaning to make the surface of the main pipe fully lubricated.

Warning

Improper operation of the shock absorber may cause damage or even an explosion causing serious personal injury. For maintenance, please refer to the maintenance scheduled on page 10.2. Please refer to page 7.7 for adjustment.

Warning

The shock absorber contains high-pressure gas or liquid.

Do not try to tamper with or disassemble the shock absorber.

Please avoid impact, high temperature or open flame on the gas cylinder.

After riding the motorcycle, the shock absorber and the gas cylinder may be in a high temperature state, please avoid burns.

Wheels and tires

Check the wheels for the following conditions:

The rim is deformed or cracked.

There are impact marks on the rim.

Loose or deformed spokes.

There are cuts, cracks, cracks, or missing tread blocks in the tread or sidewall area.

Tyre bulge.

The tyre tread wears unevenly.

The height of the tyre line is uneven. If you find any of the above conditions, please replace the wheels or tires immediately.

Maintaining Your Motorcycle

2. Check the chain wear, tightness and lubrication

(1) Use a stand to raise the motorcycle so that the rear wheel hangs in the air. Move the chain up and down by hand and check whether the sag is within the recommended range: 35-45mm.

(2) When adjusting, first loosen the rear wheel axle nut, and then adjust the left and right adjusting bolts to make the chain tightness within the recommended range.

(3) Use an appropriate amount of chain oil or chain wax to lubricate the chain.

Caution

After adjustment, the left and right adjuster marks should be the same as the horizontal fork scale line.

Warning

Incorrect tyre pressure is a common cause of tyre failure. Long-term incorrect tyre pressure may cause tyre damage, separation of the tread or loss of control of the motorcycle resulting in serious personal injury.

Before each ride, check the tyre pressure and adjust it to an appropriate air pressure level. When the tire is cold, use an accurate pressure gauge to check the tyre pressure.

Recommended tire pressure table

status	Front wheel	Rear wheel
Off-road tires	230kPa	225 kPa
All-terrain tires	225kPa	225 kPa

Note: The recommended tire pressure range for off-road tires is 100 ~ 150 kPa in the field and forest road usage scenarios

Chain

Please refer to the maintenance interval table on page 10.2 for the inspection and maintenance of the chain

1. Keep the chain and sprockets clean

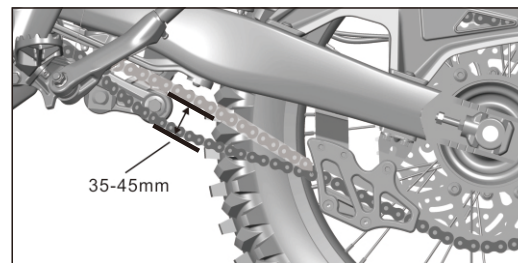

Maintaining Your Motorcycle

Chain adjustment procedure

1. Use a support stand so that the rear wheel is suspended, remove the key from the key switch and turn off the motor switch.
2. Loosen the rear axle nut 'A'.
3. Loosen the locknut 'C' of the left and right adjusting bolts 'B'.
4. Adjust the left and right adjusting bolts 'B' equally until the chain is adjusted within the specified range.
5. Tighten the rear axle nut 'A'.
6. Tighten the left and right lock nuts 'C' to fix the position of the adjusting bolt 'B'.
7. Test ride a motorcycle. 8. After the trial ride, please recheck whether the chain is adjusted correctly, and re-adjust if necessary.

Caution

When adjusting the chain, adjust the adjusting bolts on both sides equally.

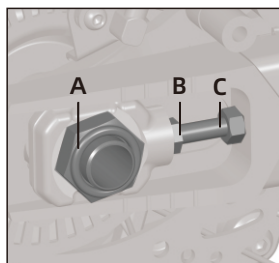

Headlight adjustment

The angle of the headlights should be checked regularly. It must be re-adjusted after changing the angle of the whole motorcycle at any time because changes in the angle of the whole motorcycle will affect the angle of the headlights. Before adjusting the headlights, the shock absorption and tyre pressure must be adjusted correctly. The illumination angle of the headlight can be adjusted vertically. If the illumination angle of the headlight is not suitable, it will cause the beam to point too close or too far.

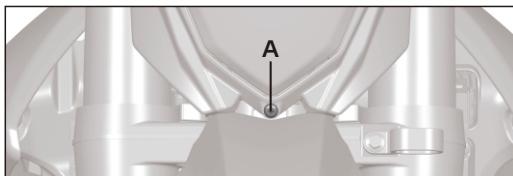

Headlight angle adjustment:

1. When the headlight is in the low beam position, the motorcycle is perpendicular to the ground,
2. With the operator sitting on the motorcycle, verify the beam angle.
3. The adjusting screw 'A' is located directly under the headlight. S

Maintaining Your Motorcycle

4. To adjust the illumination angle of the headlight, please turn the screw until the correct beam angle is reached.

5. The correct illumination angle is 0.7-0.95 meters away from the ground from the near bright and dark

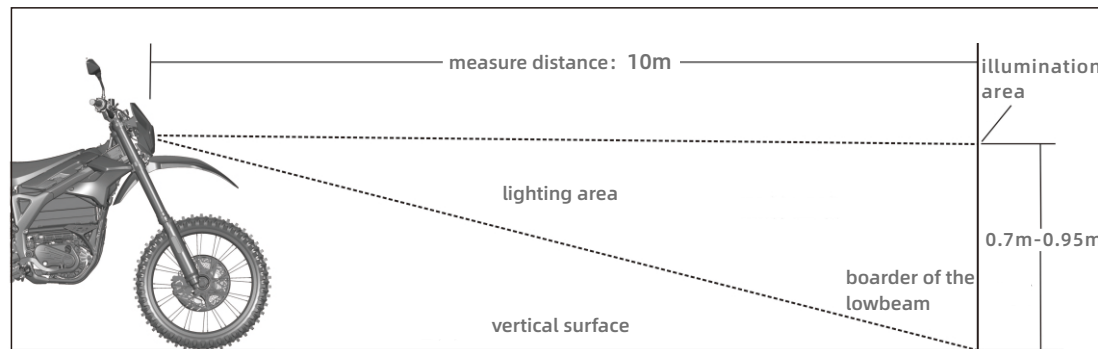

Light bulb replacement

When the front light 'A'/turning light 'B'/brake light/tail light 'C' is damaged, please contact an authorized dealer for a complete replacement.

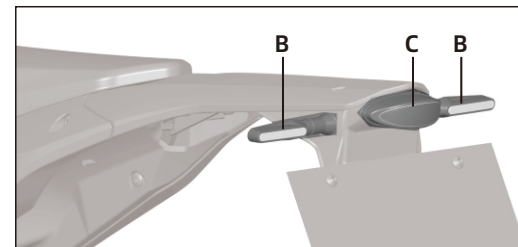
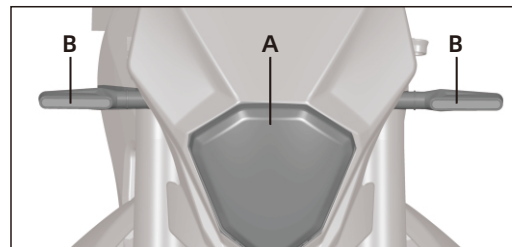

Maintaining Your Motorcycle

Motorcycle cleaning

1. Use a sponge or clean soft cloth, neutral detergent and water to gently clean the motorcycle.
2. Be extra careful when cleaning the dashboard-board, it is easier to scratch than other parts of the motorcycle.
3. After cleaning, rinse the motorcycle thoroughly with water to remove all detergent residues.
4. Dry the motorcycle with a soft dry towel.
5. After cleaning, check for damage, wear or leakage.

After cleaning the motorcycle, please maintain the chain and other parts that need to be lubricated. Please let all electrical components dry before operation. If the Storm bee electric motorcycle is to ridden immediately after cleaning, use the brakes several times at a safe and low speed to remove the water on the brake pads.

Note

Improper cleaning can damage motorcycle parts. Do not use high-pressure water guns to flush bearings, seals, electrical components and plugs. In order to prolong the

service life of the Stormbee electric motorcycle, it should be cleaned and maintained regularly and it is recommended to wipe it dry as soon as possible after cleaning.

Do not use any harsh chemical products on plastic parts. Avoid using strong corrosive cleaners, solvents or thinners, fuel (gasoline), rust removers or inhibitors, brake fluid, antifreeze, or electrolytes that have been in contact with cloth or sponges.

We recommend that you do not use a high-pressure water gun to clean the Stormbee electric motorcycle to avoid damaging certain parts.

Warning

After cleaning and before starting to ride, be sure to test the brakes.

Wheel and tire cleaning

Avoid using strong acid wheel cleaners. If you use this type of product to clean stubborn dirt, please try to clean it in a short time and dry it immediately.

Warning

Any tyre maintenance products may reduce the friction

between the tyre and the ground, and even cause the tyre to age prematurely.

Parking and long-term storage

For motorcycles that have not been used for a long time (more than 30 days), it is recommended to charge to about 60% to 80% of the battery power, and disconnect the cable between the Storm Bee electric motorcycle and the battery pack.

The battery pack also discharges slowly when stored. Check the power of the battery pack at least once every 1 month. If the power drops below 30%, it should be recharged to 60% to 80%. When you are ready to use the Storm Bee electric motorcycle again, please fully charge the battery pack to ensure that the battery pack is restored to its best condition.

In order to prolong the service life of the power system, the Storm Bee electric motorcycle should be stored in a cool and ventilated place. Storing the Storm Bee electric motorcycle in a hot or humid place will shorten the life of the battery pack and electrical system. For more information about batteries and electrical systems, see page 8.1.

Maintaining Your Motorcycle

Caution

Do not store the Storm bee electric motorcycle with a battery power lower than 30%. Discharging the battery pack below 30% for a long period of time may reduce the life of the battery pack or even damage the battery pack. Damage to the battery pack caused by over-discharge or long-term extremely low power is not covered by the warranty.

Warning

Only professionally trained technicians can provide maintenance services to the battery pack. Please note that unauthorized handling of the internal components of the battery pack may be dangerous. Do not disassemble!

Storm Bee electric motorcycle parts

Storm Bee electric motorcycles require the use of accessories specified by the manufacturer. Through your dealer, you can obtain original spare parts for maintenance of the Storm Bee electric motorcycle.

Fuse

The motorcycle electrical system has a multi-channel overcurrent protection device. The fuse used is a

Maintaining Your Motorcycle

one-time protection device, which will fuse and protect when the circuit is overloaded. When replacing the fuse, use the same specification model.

Caution

If the fuse blows repeatedly, please contact the dealer to check the electrical system.

Low voltage fuse box

The low voltage fuse box is located at the left rear of the steering column.

The fuse has a protective cover, which must be opened first to access the fuse. To open the cover, press down firmly on the tab, and then open the cover.

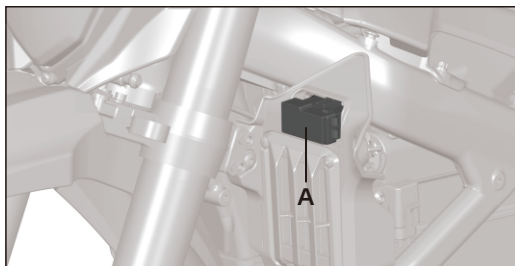

Replace a Low voltage current fuse:

1. Pinch the fuse box cover and open the box cover to the right of the fuse box.
2. To replace the fuse, you need to replace the fuse of the same specification.

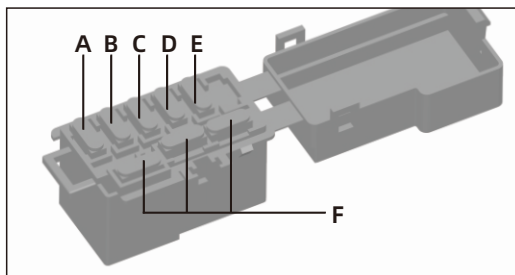

The functions corresponding to the 12 volt fuse are listed below:

	Amp	Purpose
A	5A	USB power input fuse
B	15A	ABS Motor fuse
C	15A	ABS Power fuse
D	10A	Signal system fuse
E	5A	DC1 Fuse
F	5A/10A/15A	Backup fuse

Maintaining Your Motorcycle

High voltage fuse box

The high-voltage fuse box 'A' is located in the left side shield of the motorcycle body.

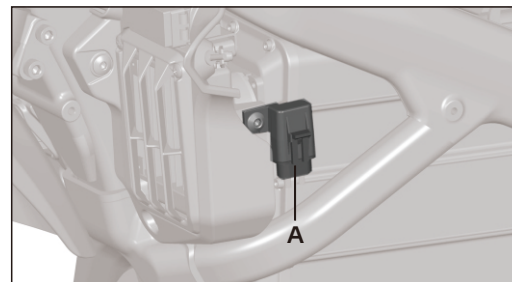

Replace the high-voltage fuse:

1. Disconnect the battery pack from the motorcycle circuit and take out the battery pack
2. Open the bayonet and remove the fuse holder 'A'.
3. Replace the fuse. The model of the high-voltage fuse is 5A

Caution

Please wear insulated gloves to replace and be careful to disassemble and assemble to avoid damage.

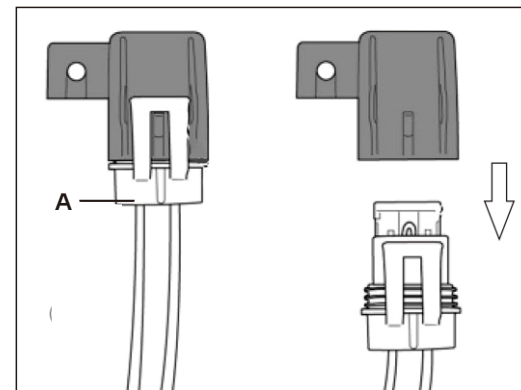

Electric Circuit diagram

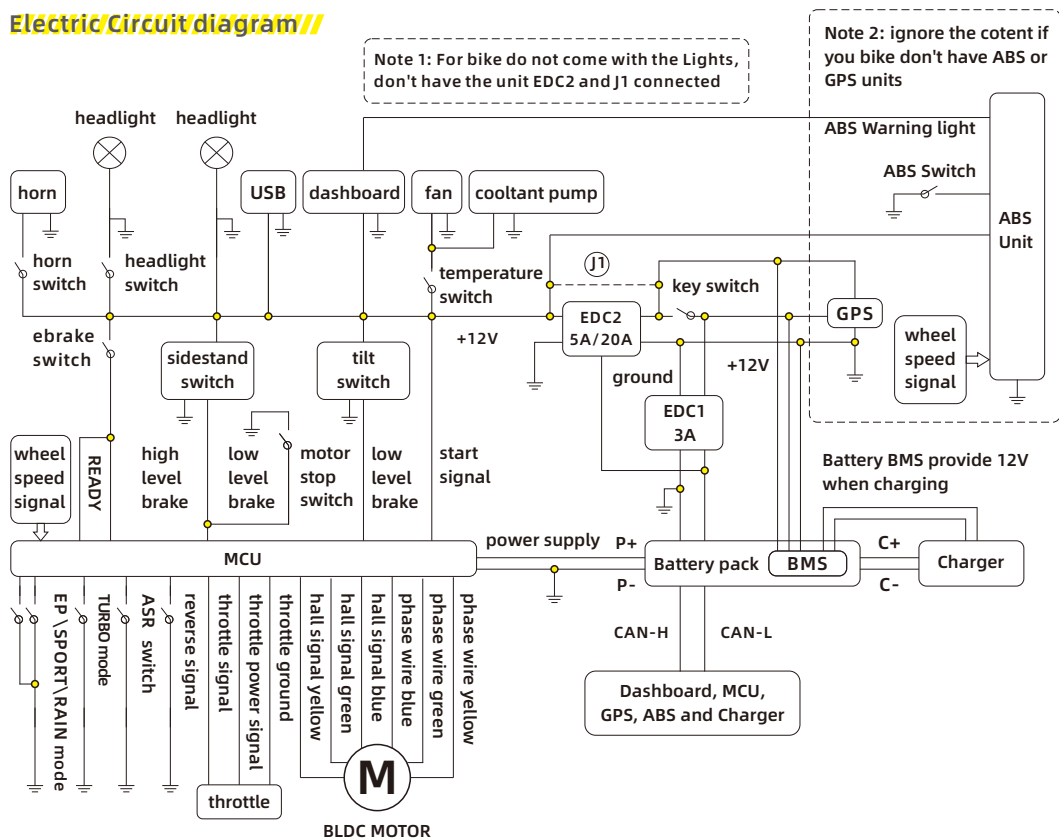

Storm Bee electric motorcycle

trouble shooting

All Storm Bee electric motorcycles are carefully inspected before delivery. Even if the Storm Bee electric motorcycle is inspected, some technical problems may occur.

The following information provides guidelines to help you identify problems and do the basic maintenance. If you are unable to solve the problem by yourself, please bring it to an authorized dealer at your convenience. If there is no dealer in your area, call the manufacturer customer service.

Temperature Precautions

cold weather

The cold weather will not permanently affect battery capacity; However, riders may find their range and power reduced as cold temperatures have an impact on the amount of energy the battery pack can release.

Therefore, when used in an environment below 0°C compared to an environment at 25°C, the motorcycle may temporarily reduce its range by around 30%.

In extreme cold weather, the Storm Bee motorcycle

may also temporarily reduce power and fail to reach top speed

It is not recommended to ride the motorcycle when the battery pack temperature is below -5°C. If used at low temperatures, the battery pack must be placed at temperatures above 0°C for charging. The battery management system does not allow the battery pack to discharge below -20°C, it's the standard specified by the battery manufacturer.

It is recommended to store the Storm Bee Electric Motorcycle in a suitable temperature environment

It can be stored in thr following conditions:

- 1.temperature should not be lower than -20°C, better above 0°C.
- 2.Before storage, charge the battery pack to 60% ~ 80% of the power state. You should check its power state at least once a month. If the battery pack power drops below 30%, it should be recharged to 60% ~ 80%.
- 3.The battery pack can only charge at temperatures above 0°C.

Storage temperatures below -20°C may permanently lower battery pack performance. Keep the

Troubleshooting

temperature above -20°C and following long-term storage guidelines (see 'Stop and long-term storage' on page 10.16) will ensure that the battery pack is in good condition during winter storage.

Caution

In order to prevent battery pack damage during charging, the battery management system will prevent the charger from charging the battery pack at temperatures below 0°C. Similarly, damage to the battery pack can be avoided as long as the battery pack is kept at temperatures above -20°C in the winter and at more than 30% of the charge.

hot temperature

In high temperatures, the battery won't have any performance changes. However, when the battery temperature is higher than 68°C (subject to the standard), the battery management system will turn off the output to avoid damage. The charger will protect the battery pack by lowering the charging power when battery temperature above 50°C, which may increase the charging time. When the battery temperature exceeds 60°C, the battery management system will no longer allow charging.

Caution

Please do not place the Electric Motorcycle or its battery in an environment higher than 41°C or in direct sunlight for an extended period of time, which may accelerate the degradation of battery performance

Safety interlock

If the battery management system detects a serious internal failure, one or both of two measures will be taken to prevent damage to the battery pack:

Prohibited the use. If the battery pack charge is zero, or if the battery management system detects some serious internal problems, the motorcycle will be prohibited from use until the problem is resolved.

Charging is prohibited. If the battery management system detects some serious internal problems, it will prevent charging, even if the battery pack is connected to the charger and plugged into AC power until the problem is resolved.

Precautions for Storm Bee electric motorcycle

Storm Bee Electric Motorcycle has a high voltage component. Take proper precautions when using it. The high voltage used in these components is

dangerous and can result in burns, electric shocks and even serious personal injury.

For safety purposes always follow the instructions on the label attached to the motorcycle parts and do not touch or attempt to remove or replace any high voltage parts, wiring (marked by the orange outer bushing) or connectors. In the event of an accident, do not touch any high voltage terminals or components connected to the wires. In case of a fire on the Electric Motorcycle, secure yourself first and then use Class D fire extinguisher to put out the fire. When the flame is out, use plenty of water or a water-based fire extinguisher to cool it down.

Warning

Your Electric Motorcycle uses a high voltage of 90V. At the same time, the power system may be too hot to touch after work. Beware of high pressure and high temperatures and obey all the safety rules.

Serious warning

The high voltage circuit system of the Electric Motorcycle is not allowed to be maintained by the user. Removing and replacing high-voltage components, cables, or connectors may result in severe burns or electric shocks,

Troubleshooting

or even life-threatening injuries. High-voltage cables are labelled orange for easy identification.

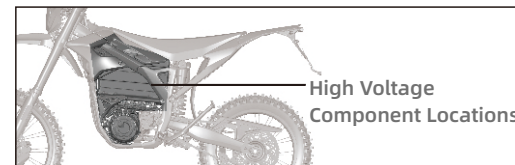

System warning message

When a fault is detected, the yellow fault indicator 'A' on the top of the instrument will light up, and the corresponding Warning Code will be displayed in the 'B' area on the LCD of the instrument.

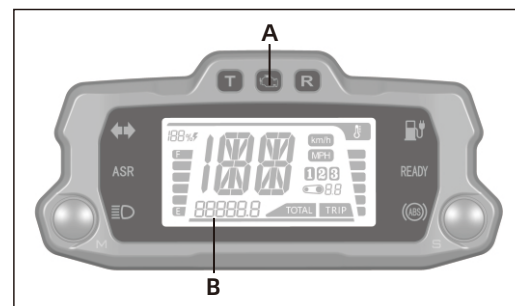

Please refer to the table starting on the next page for possible causes and solutions.

ERROR/CODE/CHART//

ERROR CODE	ERROR DISCRIPTION	SOLUTION
ER-000	Dashboard data communication protection	Check dashboard wire connection
ER-003	Over discharge protection (level 2)	Bike enter Low Power Mode, check if motor is in locked rotor condition.
ER-004	REGEN overcurrent protection (level 2)	Lower REGEN setting
ER-008	Battery discharge relay over temperature protection (level 2)	Stop using the bike and contact manufacturer or authorized dealer
ER-010	Battery charge relay over temperature protection (level 2)	Stop charging and contact manufacturer or authorized dealer
ER-011	Startup self-test over temperature protection (level 1)	Turn OFF the key switch and back to ON again
ER-013	Battery cell temperature unbalance protection (level 2)	Stop using the bike and contact manufacturer or authorized dealer
ER-015	Battery pack insulation protection (level 2)	Stop using the bike and contact manufacturer or authorized dealer
ER-017	Battery cell volume unbalance protection (level 2)	Contact manufacturer or authorized dealer
ER-019	Battery cell under voltage protection (level 3)	Charging the battery pack
ER-022	Over discharge protection (level 3)	Stop using the bike and contact manufacturer or authorized dealer
ER-024	Battery cell discharge over temperature protection (level 3)	Stop using the bike and wait until the temperature back to working condition

ERROR CODE	ERROR DISCRIPTION	SOLUTION
ER-025	Battery cell discharge under temperature protection (level 3)	Stop using the bike and wait until the temperature back to working condition
ER-030	BMS protection board 1 error	Contact manufacturer or authorized dealer
ER-031	BMS protection board 2 error	Contact manufacturer or authorized dealer
ER-037	Battery hall sensor error	Contact manufacturer or authorized dealer
ER-038	Battery voltage sensor error	Contact manufacturer or authorized dealer
ER-040	Battery all temperature sensor error	Contact manufacturer or authorized dealer
ER-041	Startup self-test temperature sensor error	Contact manufacturer or authorized dealer
ER-042	Relay temperature sensor error	Contact manufacturer or authorized dealer
ER-043	Battery discharge relay error	Contact manufacturer or authorized dealer
ER-044	Battery charge relay error	Contact manufacturer or authorized dealer
ER-100	MCU electron tube error	Contact manufacturer or authorized dealer
ER-101	MCU over current protection (level 1)	Bike enter Low Power Mode
ER-104	Motor hall sensor error	Contact manufacturer or authorized dealer
AL-105	Motor locked rotor error	Check if motor or motor reducer is in locked rotor condition

Troubleshooting

Troubleshooting

ERROR CODE	ERROR DISCRIPTION	SOLUTION
ER-106	MCU sampling error	Contact manufacturer or authorized dealer
ER-107	MCU over temperature protection (level 2)	Bike enter Low Power Mode
ER-108	Motor over temperature protection (level 2)	Bike enter Low Power Mode
ER-109	MCU power failure protection	Check key switch and fuse
ER-110	Battery pack Low voltage protection (level 3)	Charging the battery pack
ER-111	Battery high voltage protection	REGEN function disabled
ER-112	Low level SOC protection (level 3)	Charging the battery pack
ER-113	Battery cell over/under temperature protection (level 3)	Stop using the bike and wait until the temperature back to working condition
ER-114	Throttle signal protection	Check if throttle cable is short circuited or unable back to idle position
ER-115	Throttle ground protection	Check if throttle cable is short circuited, cable damaged or broken
AL-116	High level brake protection	Check if e-brake is short circuited
AL-117	No.1 Low level brake protection	Check if side stand switch is still ON
AL-118	No.2 Low level brake protection	Check tilt switch
ER-127	Motor temperature sensor error	Contact manufacturer or authorized dealer
AL-128	REGEN turned OFF	Check battery temperature and battery voltage
ER-129	CAN communication error	Check all wire and cables

Troubleshooting ///

symptom	Potential cause	
Bike does not turn on	Battery not plug into correct position	Check battery plug
	SoC too low	Charing the battery
	Battery enters temperature protection	v (-20°C to 65°C)
	Fuse blown	Check all wire and cables and replace fuse
	Key switch not properly engaged	Recheck key switch or replace new key switch
	DC converter error	Replace DC converter
	Battery malfunction	Contact manufacturer or authorized dealer
Bike powered on but not moving	Side stand switch protection	Side stand up
	e-brake protection	Check e-brake
	Tilt sensor was triggered but not reset	Switch off the key switch and turn on again after lift up the bike
	Throttle not in idle position when startup	Check throttle position
	Battery low Soc protection	Charging the battery
	Motor temperature protection	wait until the temperature back to working condition
	MCU temperature protection	wait until the temperature back to working condition
	Side stand switch error	Disconnect or replace side stand switch
	e-brake error	Disconnect or replace e-brake

Troubleshooting

symptom	Potential caus	Potential cause
Bike powered on but not moving	Tilt sensor error	Disconnect or replace tilt sensor
	Throttle error	Replace throttle
	MCU not plug in position	Check MCU plug
	Motor hall not plug in position	Check motor hall plug
	MCU or motor hall sensor error	Replace MCU Replace motor
Bike start ok but battery SoC not display	Coulombmeter not connect properly	Contact manufacturer or authorized dealer to repair battery
	Coulombmeter error	Contact manufacturer or authorized dealer to repair battery
Charger not working	Battery enters temperature protection	wait until the temperature back to working condition
	A/C power missing; charger not plug properly	Check power source and plug again
	Charger malfunction	Replace charger
	Battery malfunction	Contact manufacturer or authorized dealer
riding mode malfunction and power reduced	Low battery	Charge battery
	Battery temperature protection	wait until the temperature back to working condition
	MCU or motor temperature protection	wait until the temperature back to working condition
	Riding mode switch error	Replace riding mode switch

Troubleshooting

symptom	Potential caus	Potential cause
USB port no power	USB not plug properly	Check USB connection and plug again
	USB converter error	Replace USB converter

Note: We will keep updating all the informations above, please check latest version on our website.

Warranty and after-sales information

CONDITION OF WARRANTY

SURRON hereby warrants new SURRON bike purchased from an authorized SURRON dealer to be free from defect in materials and workmanship for the period of time stated herein, subject to certain limitations stated herein. This warranty applies only if the bike has been properly set-up and serviced for pre-delivery by an authorized SURRON dealer. The warranty applies only if the motorcycle has been operated and maintained in accordance with the owner's manual or other SURRON literature delivered with the bike. This warranty is void if the ONLINE OWNER'S REGISTRATION/ DEALER PRE-DELIVERY INSPECTION has not been completed in full and entered into SURRON Distributor website within 7 days of purchase by the original selling dealer.

PERIOD OF WARRANTY FOR SURRON MOTORCYCLES

Duration: 12months (24 months for battery only) from date of purchase or 5,000miles, whichever comes first.

Limitations: This warranty is not transferable and applies to the original purchaser only.

Applies to: Storm Bee All Terrain (R), Storm Bee

Enduro (E)

Off-road used motorcycles but not used in Competition:

Duration: 6 months from date of purchase.

Limitations: This warranty is not transferable and applies to the original purchaser only.

Applies to: Storm Bee Enduro (E), Storm Bee Off-Road (F)

Competition motorcycles or any other SURRON models used in Competition:

Duration: 30 days from date of purchase.

Limitations: This warranty is not transferable and applies to the original purchaser only.

Applies to: Storm Bee Enduro (E), Storm Bee Off-Road (F)

Any SURRON motorcycle utilized commercially in connection with generating income and/or is commercially licensed or tagged (e.g., Rental, Wholesale etc.,) during the warranty period will be covered for 30 days from the date of purchase. The warranty period is effective on the date of purchase by the Original Purchaser and remains in effect only as stated above.

Warranty and after-sales information

PARTS COVERED BY THE WARRANTY

SURRON warrants to the customer that the motorcycle is defect-free both in terms of material and workmanship from the factory. Any part found to be defective during the motorcycles stated warranty period subject to the limitations of this warranty policy will be repaired or replaced free of charge.

WARRANTY LABOUR COVERAGE

Labour to replace parts that are covered in the SURRON warranty, which are found to be defective in material or workmanship, is no charge to the original purchaser. Warranty repairs must be done only with the authorization of SURRON.

GENERAL EXCLUSIONS FROM WARRANTY

This warranty does not cover any failures resulting from, or caused by:

- 1.Lack of proper maintenance or contrary to the requirements described in the Owner's Manual.
- 2.Modification, alterations, and installation of parts that are not genuine SURRON parts or supplied as original equipment.
- 3.Parts or components damaged by use or operation

under abnormal circumstances, damages due to accident, collision, abuse, neglect or exceeded use like Competition level.

4.Modification, alterations, and installation of not genuine SURRON or SURRON authorized Power System like motor, gearbox, battery and MCU.

5.Normal wear components, including but not limited to, the following: tires, brake components, drive chain, handle grips, all bearings, all seals, all transmission gear, suspension valving/seals, all sprockets, foot pegs and seat.

6.Damage, malfunctions, or performance problems caused by continued operation of the motorcycle after an error code shown or other warning indicates a mechanical or operational problem

7.Misuse, such as, but not limited to, using not suitable lubricants and coolants etc.

8.Damages or malfunctioned to the component and electric system due to owner installing non genuine SURRON parts or replacement parts not approved by SURRON.

9.Damages to the paint, coatings or corrosion of metal parts due to external influences such as stones, salt. Fading or painted or metal coated

Warranty and after-sales information

surfaces. In addition, SURRON warranty are only for end-user customers, not applicable to bike or accessories not imported or distributed by SURRON or authorized by SURRON.

OWNER/RESPONSIBILITY///

1. Owner is responsible for maintaining their motorcycle in accordance with the schedule printed in the Owner's Manual.

2. Owner is responsible for the costs of maintenance to the motorcycle including service at scheduled intervals. Service work done by the owner will void the warranty. Failures caused directly by lack of maintenance or improper maintenance will void the warranty.

3. If warranty repairs are needed, they must be performed by an authorized SURRON dealership with correct qualifications. The owner may be asked to provide the following documentation of proper maintenance: a maintenance record which displays the date of service and service work performed by an authorized dealer, copies of repair orders/receipts.

4. The original registered owner as documented on the SURRON motorcycle warranty registration form is

responsible for conveying the Owner's Manual and all safety warnings, instructions, and Limited Warranty if the unit is sold, loaned, or otherwise transferred to another person.

5. Return the SURRON motorcycle or parts to an authorized SURRON dealer within ten (10) working days after discovery of any defective parts. Your SURRON dealer should initially determine if the particular SURRON component(s) in question are to be submitted to SURRON for evaluation. All warranty work must be performed by an authorized SURRON dealer.

6. Owner is responsible for performing all recommended and necessary routine care and maintenance and engage in proper use of your SURRON motorcycle and Battery pack as detailed in the Owner's Manual including obtaining any firmware updates available at each service interval or in a timely basis following a notification that a new update is available of which must be completed by an authorized SURRON dealer. Learn and obey all federal, state, and local laws governing the operations of a motorcycle, generally, and an electric motorcycle, specifically.

7. SURRON does not authorize any company or

Warranty and after-sales information

person to create a liability or any warranty obligation on its own behalf. SURRON in its sole discretion will make the final disposition of any component(s) submitted for warranty evaluation. All parts and components returned to SURRON, and replaced under this warranty shall become the property of SURRON

LIMITATIONS/ON/WARRANTY///

The limited warranty described in the Warranty information pages is the only warranty which applies to your motorcycle. SURRON makes no other warranty or guarantee of any kind expressed or implied. no implied warranties of merchantability or fitness for a particular purpose or any purpose, is applicable to any product sold by SURRON buyer and all other parties who contract with SURRON, hereby specifically and knowledgeably waive any and all warranties, expressed or implied. This limited warranty does not cover any incidental or consequential damages, including loss of value of the motorcycle, lost profits or earnings, out-of-pocket expenses for substitute transportation etc., expenses associated with returning the covered product back to its owner, mechanic's travel time or communication charges, loss or damage to personal

property, loss or time, or inconvenience. SURRON has the right to continuously upgrade the design and electric system or improve not limited to the motorcycle, power system or battery pack. Some countries do not allow limitations on how long an implied warranty lasts, so the above limitations may not apply to you. also excluded from this warranty are any incidental or consequential damages including loss of use. some countries do not allow the exclusion or limitation of incidental or consequential damages, so the above exclusion may not apply to you. This warranty gives you specific legal rights, and you may also have other rights, which vary, from country to country. The contents stated herein are subject to change without notice.

HOW TO OBTAIN WARRANTY/SERVICE///

To receive any type of warranty service, take your SURRON motorcycle and warranty registration proof to any authorized SURRON dealer during normal service hours. If you believe that your vehicle has a defect which could cause a crash or could cause injury or death, you should immediately inform SURRON or your SURRON authorized dealer. If you fail or does not meet the conditions and scope of the

Warranty and after-sales information

warranty terms, we can still provide repair services upon your request with certain charge. If you are unable to get satisfactory warranty service at a SURRON dealer, or you are dissatisfied with a warranty decision, please write e-mail to the following address:

service@qiulongtech.com

Note: We will complete the warranty work as soon as possible, but not responsible for delays in work caused by factors beyond our control. The aforementioned factors include but are not limited to: shortage of spare parts, delay in transportation, force majeure, etc.

12.5

12.6

Schedule

Schedule

After you have had your Motorcycle serviced, please make sure that the appropriate maintenance record has been completed. Use the space "Remark" to record issues you want to remind yourself about or mention at the next service.

100KM

Odometer reading		Performed by		Date	
Maintenance Record Sheet					
Remark					

500KM

Odometer reading		Performed by		Date	
Maintenance Record Sheet					
Remark					

1000KM

Odometer reading		Performed by		Date	
Maintenance Record Sheet					
Remark					

2000KM

Odometer reading		Performed by		Date	
Maintenance Record Sheet					
Remark					

5000KM

Odometer reading		Performed by		Date	
Maintenance Record Sheet					
Remark					

13.5

10000KM|12 months

Odometer reading		Performed by		Date	
Maintenance Record Sheet					
Remark					

13.6

Schedule

Schedule

After-sales services record sheet					
	Odometer reading	warranty item	Performed by	Date	Remark
1					
2					
3					
4					
5					

After-sales services record sheet					
	Odometer reading	warranty item	Performed by	Date	Remark
6					
7					
8					
9					
10					

13.7

13.8

Comparison Table of Export model parameters

versions/spec	STORM BEE R (road)	STORM BEE E (enduro)	STORM BEE F (off road)
Dimension:	2075mm×805mm×1240mm	2120mm×805mm×1265mm	2070mm×805mm×1240mm
Ground clearance:	315mm	335mm	285mm
Seat height:	950mm	975mm	910mm
Dry/Curb weight:	104kg/136kg	100kg/132kg	95kg/127kg
Carrying capacity:	107kg	107kg	120kg
Front tire	110 / 80-19 All terrain tire	80 / 100-21 off road tire	80 / 100-21 off road tire
Rear tire	140 / 70-17 All terrain tire	100 / 90-18 off road tire	100 / 90-18 off road tire
Assistance functions:	ASR + BERS + ABS (optional)	ASR + BERS+ ABS (optional)	ASR+BERS
Wheel base:	1430mm		
Front fork travel:	290mm		
Rear shock/wheel travel:	115/290mm		
Power system:	Mid-drive BLDC motor + FOC sine wave controller		
Rated power:	10KW		
Maximum power:	22.5KW		
Maximum torque:	520N.m		
Top speed:	110km/h		
range	100Km (@50km/h)		
Battery Type:	90V/48Ah lithium-ion removable battery pack		
Charge time:	4h		
Frame design:	aluminum forged frame		
Riding mode:	Eco / Rain / Sport mode + "Turbo " mode		

13.11

